

mira

Combiflow

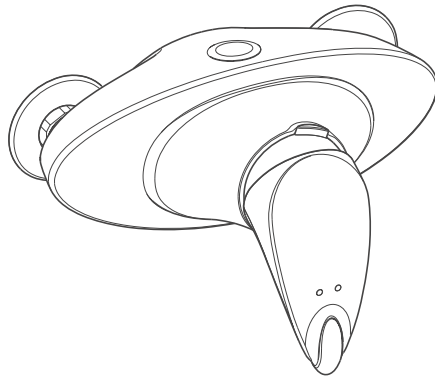
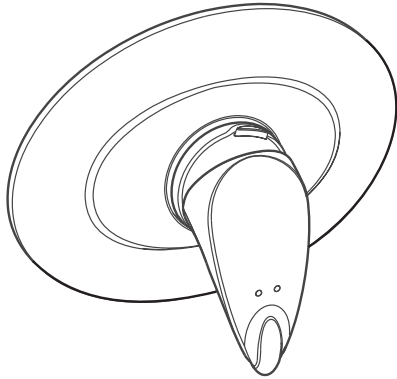

MIRA COMBIFLOW

SHOWER CONTROL

Installation & User Guide

These instructions are to be left with the user

CONTENTS

Introduction	3
Important Safety Information	4
Pack Contents Checklist	5
Dimensions	7
Specifications	8
Pressure Range	8
Temperatures	8
Connections	8
Standards and Approvals	8
Installation Requirements	9
Installation	14
Combiflow	14
1. Rear Inlet Supplies (rising or falling concealed pipework)	14
2. Exposed Inlet Supplies (rising or falling surface pipework)	17
Combiflow B	22
3. Solid and dry-lined walls	22
4. Stud Partitions and Shower Enclosures (Front Face)	29
5. Laminated Panels and Shower Enclosures (Rear Face)	30
Reversed Inlet Connections	32
Commissioning and Control Assembly Installation	34
Flow Regulator Installation and Filter Access	34
Shroud Fitting and Removal	35
Maximum Temperature Setting	36
Adjusting Maximum Temperature Stop	38
Temperature Override Button - Disable	39
Lever Control Installation	40
Operation	41
Fault Diagnosis	42
Maintenance	45
Spare Parts	46
Accessories	50
Customer Service	Back Page

INTRODUCTION

Thank you for purchasing a quality Mira product. To enjoy the full potential of your new product, please take time to read this guide thoroughly, having done so, keep it handy for future reference.

The Mira Combiflow is a pressure balanced shower valve with lever control which maintains a constant **outlet temperature** irrespective of changes of **inlet pressures** as long as the **inlet water temperatures** remain the same. It is not a thermostatic shower control and does not sense supply temperature variations. Therefore, inlet water temperatures especially the hot, should remain relatively constant.

The Mira Combiflow can be installed with the following packages:

- Fully modulating multipoint gas water heaters.
- Fully modulating combination boilers.
- Unvented mains pressure systems.
- Mains pressurised, instantaneous hot water heated from thermal store systems.
- Pumped systems.

Showering temperature and flow are adjusted by the shower lever control. The flow rate is also determined by the supply pressures available at the inlets and internal flow regulator if used (**Note!** The 8 l/min flow regulator supplied fitted is recommended for use with fully modulating combination boilers and instantaneous water heaters).

Shower controls covered by this guide:

Mira Combiflow

Surface mounted pressure balanced shower control for connection to **exposed pipework**, for **high pressure** applications (**1.0 – 5.0 bar**).

Mira Combiflow B

Built-in shower control for connection to **concealed pipework**, for **high pressure** applications (**1.0 – 5.0 bar**).

If you experience any difficulty with the installation or operation of your new shower control, then please refer to "**Fault Diagnosis**", before contacting Kohler Mira Limited. Our telephone and fax numbers can be found on the back cover of this guide.

IMPORTANT SAFETY INFORMATION

Warning!

1. Products manufactured by us are safe and without risk provided they are installed, used and maintained in good working order in accordance with our instructions and recommendations.
2. When this shower is used with a fully modulating instantaneous multipoint water heater or combination boiler the flow must be sufficient to keep the boiler ignited. Therefore, it is important to ensure that the flow lever is positioned to the fully open position. **Adjusting the flow lever to reduce the water flow while showering may result in an increase in temperature.**

Caution!

1. Read all of these instructions.
2. Retain this guide for later use.
3. Pass on this guide in the event of change of ownership of the installation site.
4. Follow all warnings, cautions and instructions contained in this guide.
5. Anyone who may have difficulty understanding or operating the controls of any shower should be attended whilst showering. Particular consideration should be given to the young, the elderly, the infirm, or anyone inexperienced in the correct operation of the controls.
6. The temperature control can be turned from **FULL HOT** to **FULL COLD**. As such, turning the control to full hot will deliver water at the hot water storage temperature.
7. When this product has reached the end of its serviceable life, it should be disposed of in a safe manner, in accordance with current local authority recycling, or waste disposal policy.

PACK CONTENTS CHECKLIST

Tick the appropriate boxes to familiarize yourself with the part names and to confirm that the parts are included.

1. Mira Combiflow Surface Mounted Shower Control

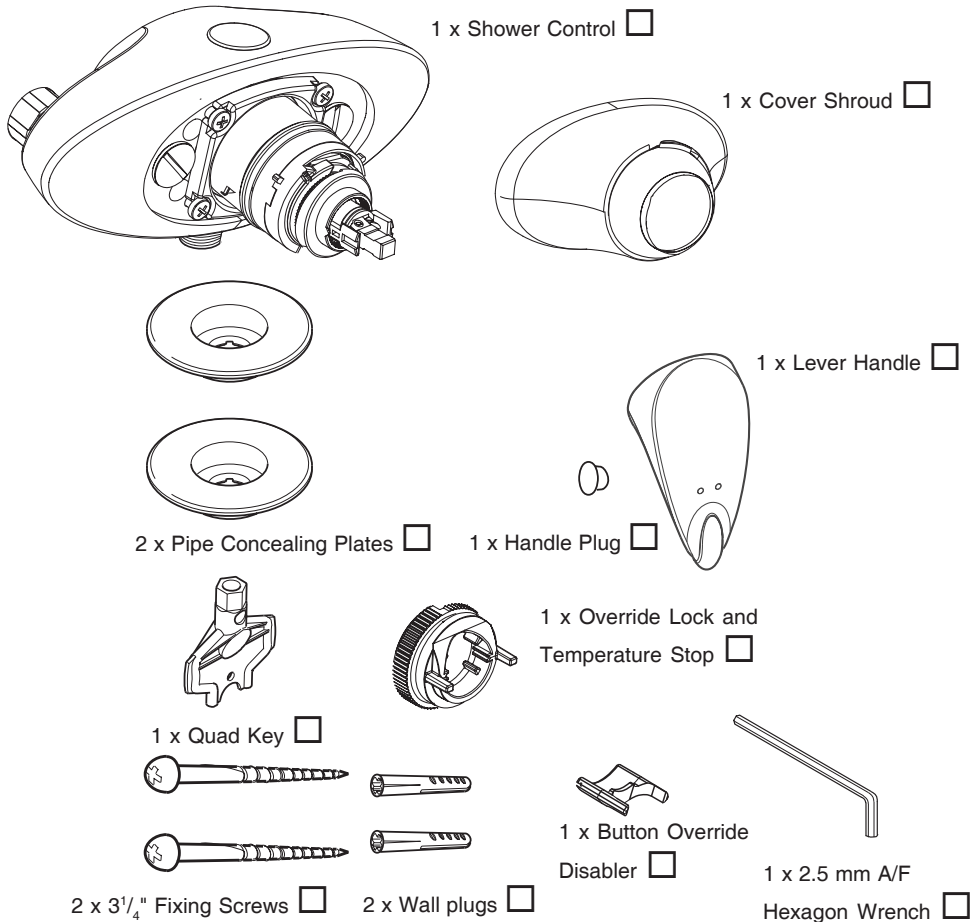

2. Mira Combiflow B Shower Control

1 x Shower Control with Building-in Cover

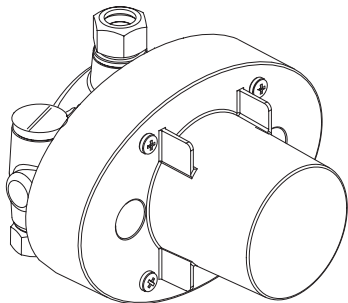

1 x Concealing Plate

1 x Foam Seal

1 x Mounting Plate Assembly

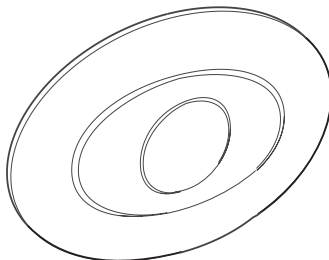

1 x Lever Handle

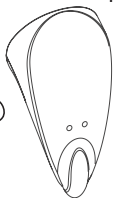

Handle Plug



2 x Bracket

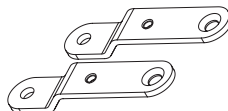

2 x M4 x 8 mm Screws



2 x No. 8 x 1 1/2" Fixing Screws



2 x Wall plugs



2 x M4 x 30 mm Screws



2 x M5 x 25mm Screws

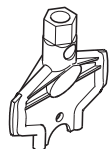

Quad Key



1 x 2.5 mm A/F
Hexagon Wrench

3. Documentation

1 x Installation and User Guide

1 x Guarantee Registration Form

1 x Installation Template

DIMENSIONS

1. Mira Combiflow

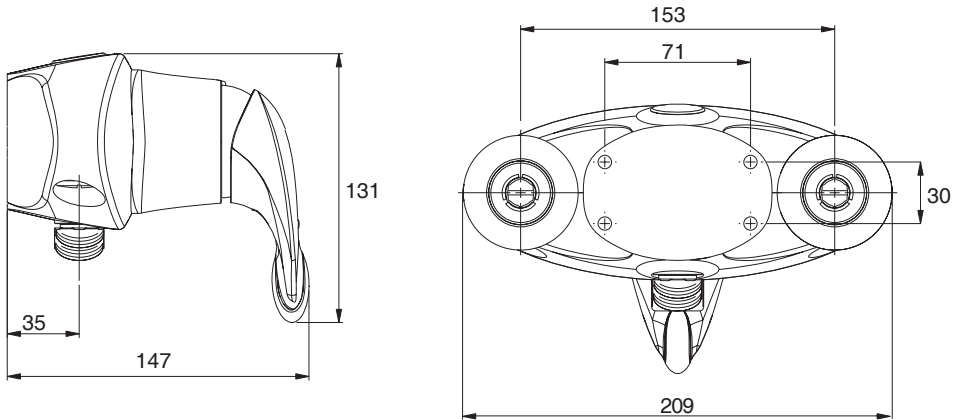

NOTE:- NOT TO SCALE - All dimensions are nominal and in millimetres

2. Mira Combiflow B

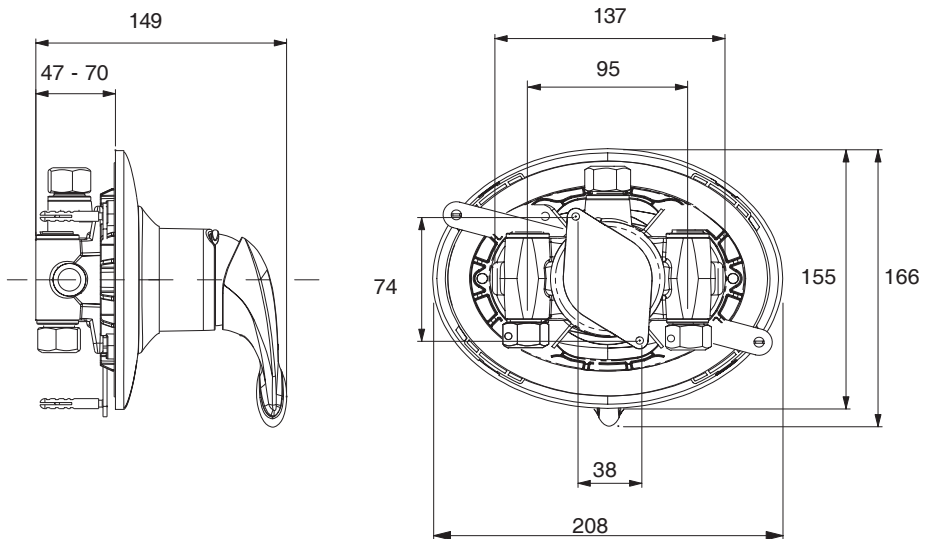

SPECIFICATIONS

Mira Combiflow and Mira Combiflow B

Pressure Range

Minimum maintained pressure: **1.0 bar**

Maximum maintained pressure: **5.0 bar**

Maximum static pressure: **10 bar**.

Note! For optimum performance, the initial supply pressures should be nominally equal.

Temperatures

Hot and cold water supply temperatures **MUST** remain relatively constant.

Maximum hot water temperature: **80°C**.

Ideally the hot water temperature should never exceed 65°C. A water temperature of 60°C is considered sufficient to meet all normal requirements and will minimize the deposition of scale in hard water areas.

Connections

Inlet

15 mm Compression (**Combiflow B**).

15 mm Compression (**Combiflow**).

Outlet

1/2" BSP male (**Combiflow**).

15 mm Compression (**Combiflow B**).

Standards and Approvals

1. Designed to be used within systems in line with BS6700.
2. BS 6700 recommends that the temperature of stored water should never exceed 65 °C. A stored water temperature of 60 °C is considered sufficient to meet all normal requirements and will minimise the deposition of scale in hard water areas.









INSTALLATION REQUIREMENTS

Read the section '**Important Safety Information**' first.

Installation must be carried out in accordance with these instructions, and must be conducted by designated, qualified and competent personnel.

1. Installations **must** comply with UK Water Regulations/ Bye-laws (Scotland), and Building and Plumbing Regulations in force at the time of installation.
2. Layout and sizing of pipework must be such that when other services are used, pressures at the shower mixer control inlets do not fall below the recommended minimum (**1 bar**). The pressure balancing performance is impaired below 1 bar. When fitted with some heater appliances the minimum maintained pressure may need to be above 1 bar, to keep the flow rate sufficiently high in order to ensure the gas flame stays lit.
3. The Mira Combiflow is **not suitable** for installation as part of a gravity-fed plumbing system (i.e. in conjunction with a hot water cylinder and cold water storage cistern), unless used in conjunction with an inlet pump producing a maintained pressure of at least 1 bar.
4. When used with a **fully modulating** multipoint or combination boiler **above 5 bar maintained pressure**, a pressure reducing valve will be necessary. For information on measuring system pressures refer to section: '**Installation Requirements, Measuring System Pressures**'. For further information on pressure reducing valves consult your local plumbing stockist.
5. Supply pipes **MUST** be flushed to clear debris before connecting the shower control.
6. Conveniently situated isolating valves are recommended to be fitted for servicing purposes.
7. If the shower control is to be used with a fully modulating multipoint water heater, fully modulating combination boiler, thermal store or unvented system an expansion vessel must be fitted to accommodate the expansion of water in the domestic hot water supply (this may already be part of the system, check the details on the boiler/heater or contact the boiler/heater manufacturer).
8. No form of outlet flow control should be fitted, only Mira recommended fittings should be used in the outlet pipework.
9. **Do not** install the product in a position in which service access is restricted.
10. **Do not** fit any form of flow control in the shower outlet.
11. **Do not** use excessive force when making connections.
12. **Do not** install the product in a position where it could become frozen.

Key to symbols appearing throughout this guide

	Float operated valve		Twin impeller inlet pump
	Stop or servicing valve		Tempering valve
	Shower control		Mini expansion vessel
	Warning or overflow pipe		Non-return Valve
	Drop tight pressure reducing valve (PRV)		

Typical Suitable Installations

1. Instantaneous multipoint water heaters and combination boilers

The shower **MUST** be installed with a multipoint gas water heater or combination boiler of a **fully modulating design** (i.e. where the water draw-off rate indirectly controls the gas flow rate to the burner).

An expansion vessel **MUST** be fitted (and regularly maintained) if any form of backflow prevention device is fitted, e.g. non-return valve, PRV. This will ensure that excess expansion or pulse pressures do not damage the product or the plumbing system. The expansion vessel may already be fitted within the boiler (check with the manufacturer) and is in addition to the normally larger central heating expansion vessel.

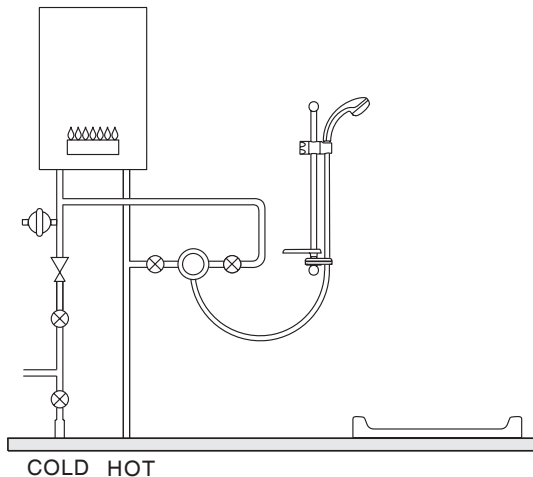

2. Unvented mains pressure showers

The shower can be installed with an unvented, stored hot water cylinder. Only a "competent person" as defined by the Building Regulations may fit this type of system.

For packages with no cold water take off after the appliance reducing valve, it will be necessary to fit an additional drop tight pressure reducing valve when the mains pressure is over 5 bar. The drop tight pressure reducing valve must be set at the same value as the unvented package pressure reducing valve.

Note! An expansion vessel **MUST** be fitted (and regularly maintained) if any form of backflow prevention device is fitted, e.g. non-return valve, PRV. This will ensure that excess expansion or pulse pressures do not damage the product or the plumbing system.

Safety devices not shown for clarity

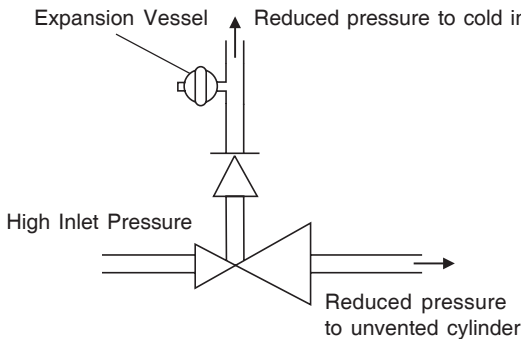
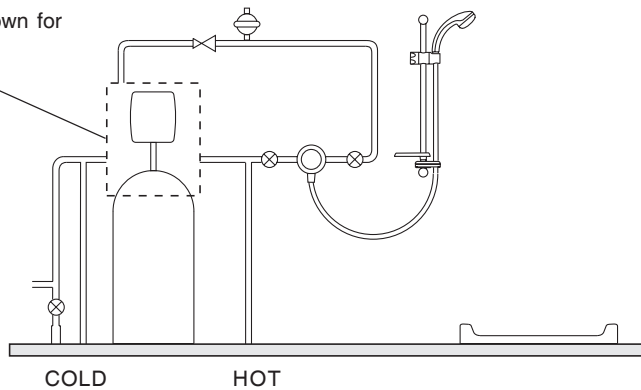

**Combined outlet PRV
with internal non-return valves
- Expansion vessel required.**

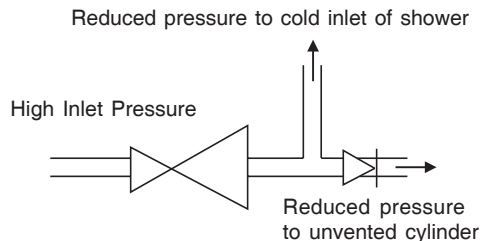

**Cold takeoff after PRV
- Expansion pressure taken up by
unvented cylinder expansion vessel.**

3. Mains pressurised instantaneous hot water shower, heated from a thermal store.

Packages of this type, fitted with a tempering valve can be used.

A drop tight pressure reducing valve **MUST** be fitted if the supply pressures exceed 5 bar maintained.

An expansion vessel **MUST** be fitted (and regularly maintained) if any form of backflow prevention device is fitted, e.g. non-return valve, PRV. This will ensure that excess expansion or pulse pressures do not damage the product or the plumbing system. The expansion vessel may already be fitted externally or internally within the thermal store (check with thermal store manufacturer).

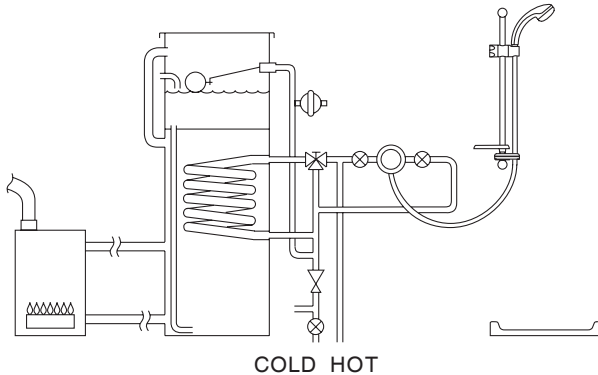

4. Pumped showers (inlet pumps)

The shower can be installed with an inlet pump (twin impeller). The pump **MUST** be located on the floor next to the hot water cylinder. The hot water cylinder/vent pipes must be arranged as shown to achieve air separation.

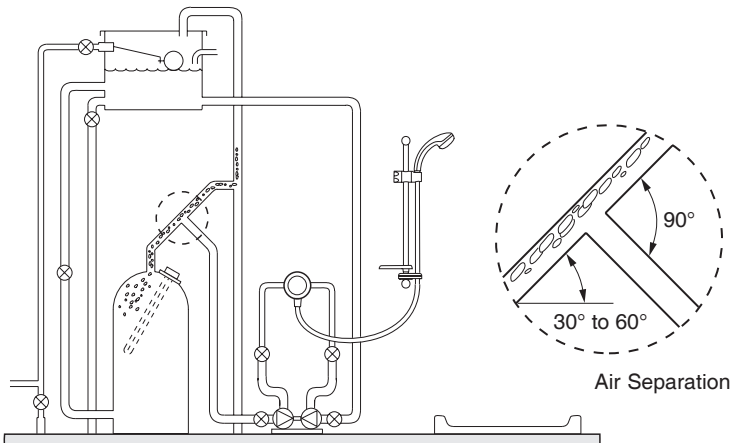

Measuring System Pressures

1. General

It is important that the system pressures are within the range specified for the Mira Combiflow (refer to section: '**Specifications**').

If the system pressure is not known then the system pressure **MUST** be measured as explained in this section.

Pressures are those present at the inlet to the appliance either whilst running (maintained) or in the off state (static). Nearby hot and cold taps connected to the same proposed feed pipes as the appliance can be used to measure the static pressure. No other fitting or appliance should be in use at this time.

Water pressures vary throughout the day, therefore you must ensure that water pressures do not drop below or exceed the minimum/maximum required (refer to section: '**Specifications**').

2. To measure static pressure (Refer to illustration below)

With the pressure testing device firmly connected to a tap drawing from one of the proposed feed pipes and the outlet from the device in the off position, the tap is turned on and the static pressure noted.

3. To measure maintained pressure (Refer to illustration below)

The pressure testing device is connected as above, the taps turned on and the outlet from the device opened until a flow of around 5 l/min is obtained (this is easily done by timing the flow into a calibrated container). The maintained pressure which can be expected when the shower is in operation can then be read. This should be carried out on the hot and cold supply.

4. To measure pressure drop

Pressure drop results from another fitting being turned on when the shower is in use. Having checked the maintained pressure as in **3.** and with the device still discharging at approximately 5 l/min, turn on a second draw-off from the same feed pipe. This new reading will show the pressure drop from **3.** and should be above the minimum maintained pressure recommended by the manufacturer.

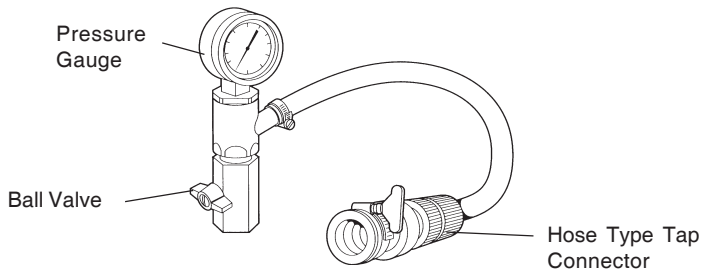

Pressure Testing Device

INSTALLATION

Combiflow

1. Rear Inlet Supplies (rising or falling concealed pipework)

Read the section 'Installation Requirements' first.

1.1 Decide on a suitable position for the shower control. The position of the shower control and the shower fittings must provide a minimum gap of 25 mm between the spill-over level of the shower tray/bath and the handset. This is to prevent backsiphonage.

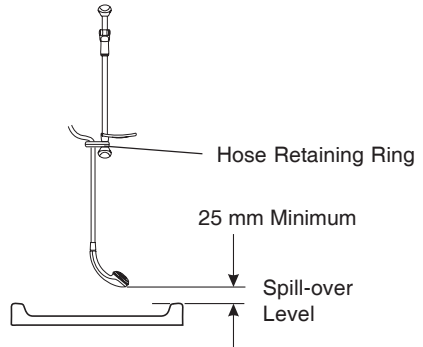

1.2 Use the installation template to mark the positions of two holes diagonally for mounting the shower mixer and the pipe centres.

1.3 For solid walls drill two holes diagonally with a 6 mm diameter drill and insert the wall plugs (supplied). For other types of wall structure alternative wall plugs may be required.

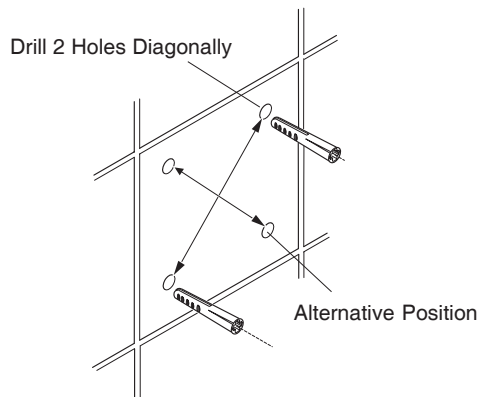
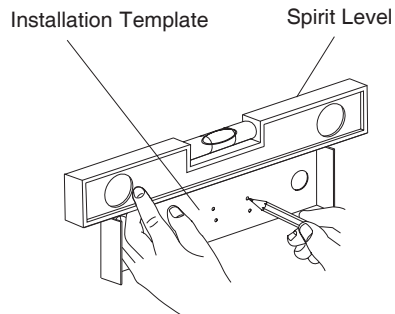

- 1.4** Use a spirit level and pencil to mark the route of the hot and cold water supply pipes at 153 mm centres.

Note! The Combiflow is supplied with inlet connections **hot left, cold right** and **bottom outlet** as standard. **For installations with reversed hot and cold supplies a reversed temperature lever will be required. Available from Kohler Mira Customer Services. It is therefore recommended that the correct pipe orientation is achieved.**

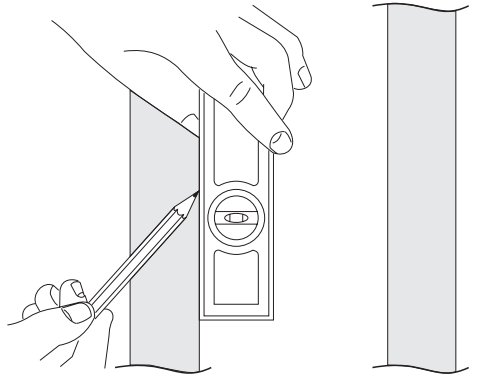

- 1.5** Remove the plaster and brick/block to the required depth to conceal the pipework.

Note! Depth must be sufficient to prevent pipe concealing plates fouling on the plumbing elbows.

- 1.6** Install the supply pipes. The pipes must project 18 mm from the finished surface of the wall at 153 mm centres.

Use the installation template to make sure that the pipes are in the right position.

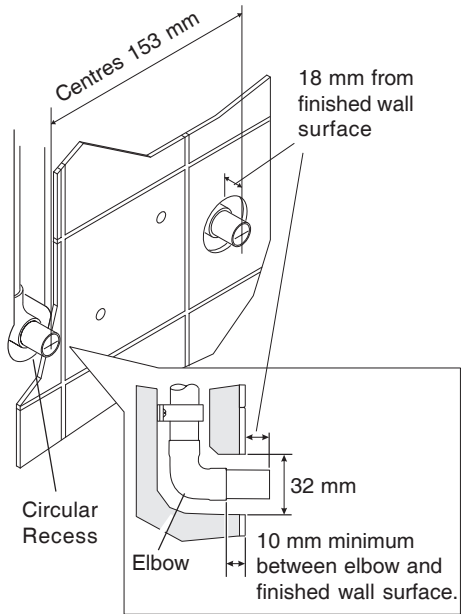

- 1.7** Finish the surface of the wall as required. The recesses from which the pipes emerge must also accommodate the 32 mm diameter x 10 mm deep flanges on the pipe concealing plates.

- 1.8** Fit the pipe concealing plates over the hot and cold supply pipes.

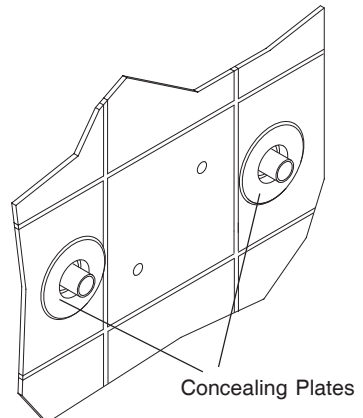

1.9 Thoroughly flush the hot and cold water supply pipes. The supplies must be clean and free from debris before connecting the shower control. Failure to do so may result in product malfunction.

1.10 Slide the compression nuts and olives over the supply pipes.

1.11 Locate the CombiFlow shower control on to the pipes and hold it in position.
Note! Make sure that the screws & wall plugs supplied with the product are used for mounting the shower.

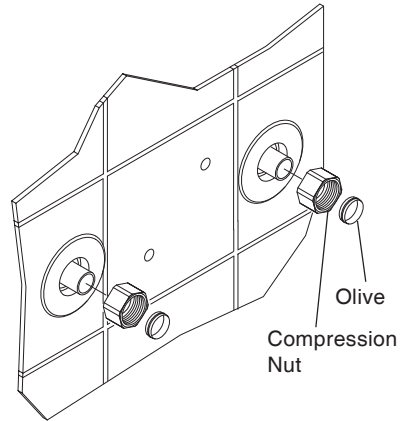

1.12 Use a suitable screwdriver to tighten the two screws through the body. The screws will hold the shower control in position.

1.13 Use a suitable spanner to tighten the compression nuts (anticlockwise rotation when viewed from front). Protect the chrome plated surfaces with a cloth.

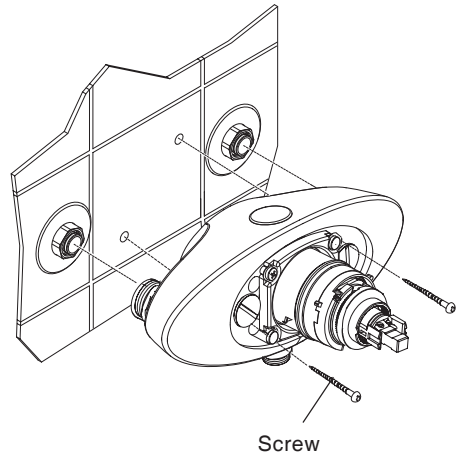

1.14 Refer to Commissioning for details on the flow regulator installation.

1.15 Turn on the water supplies and check for any leaks.

1.16 Refer to Commissioning and Control Assembly Fitting Instructions.

Shower Fittings

1.17 Install the shower fittings. Refer to the Installation and User Guide for the shower fittings.

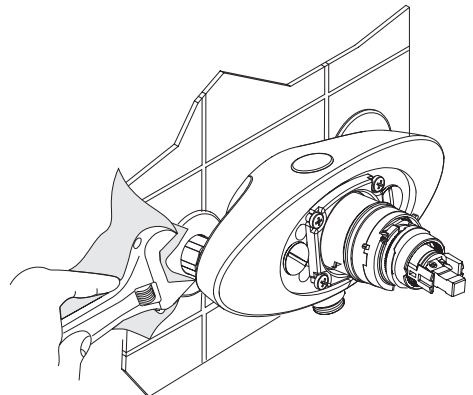

2. Exposed Inlet Supplies (rising or falling surface pipework)

Read the section 'Installation Requirements' first.

Rising Supplies

2.1 Decide on a suitable position for the shower control. The position of the shower control and the shower fittings must provide a minimum gap of 25 mm between the spill-over level of the shower tray/bath and the handset. This is to prevent backsiphonage.

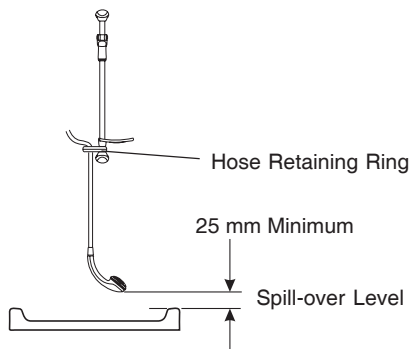

2.2 Use the installation template to mark the positions of two holes diagonally for mounting the shower mixer and the pipe centres.

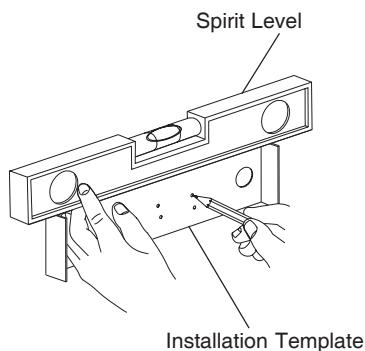

2.3 For solid walls drill two holes diagonally with a 6 mm diameter drill and insert the wall plugs (supplied). For other types of wall structure alternative wall plugs may be required.

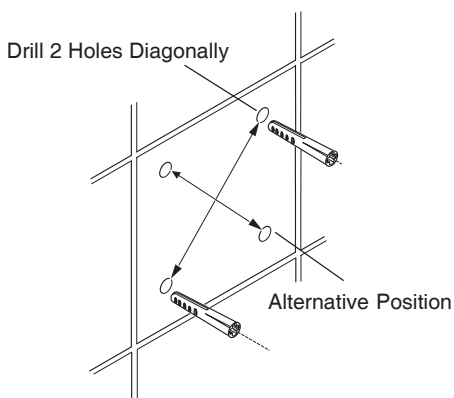

2.4 Use the quad key or a suitable screwdriver to remove the blanking plugs.

2.5 Use the quad key to remove the inlet nipples from the rear of the mixer valve.

2.6 Screw the inlet nipples, complete with 'O' seals, into the blanking plug holes flat face end first. Tighten the inlet nipples with the quad key.

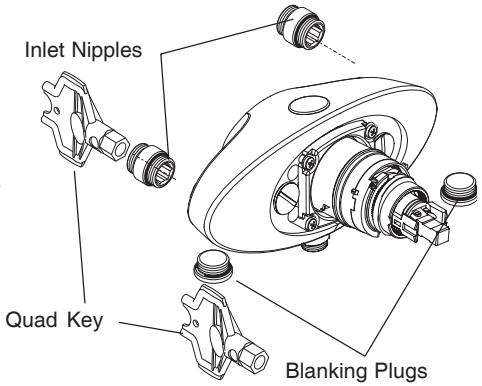

2.7 Fit the blanking plugs complete with 'O' seals, into the rear inlet nipple holes. Tighten the blanking plugs.

2.8 Locate the Combiflow shower control on to the wall.

Note! Make sure that the screws supplied with the product are used for mounting the shower.

2.9 Use a suitable screwdriver to tighten the two screws through the body. The screws will hold the shower control in position.

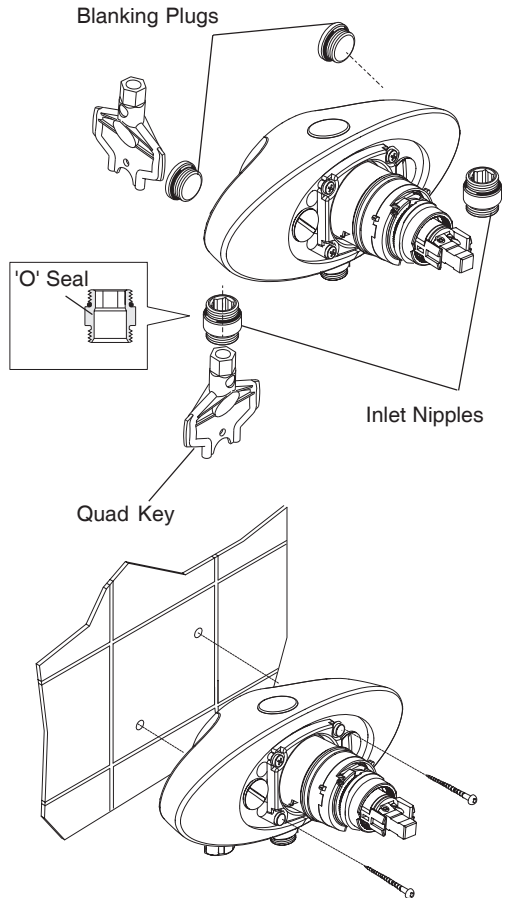

2.10 Install the hot and cold supply pipes 35 mm from the finished wall at 153 mm centres.

Use the installation template to make sure that the pipes are in the right position.

Note! The Combiflow is supplied with inlet connections **hot left, cold right** and **bottom outlet** as standard. **For installations with reversed hot and cold supplies a reversed temperature lever will be required.** Available from Kohler Mira Customer Services. It is therefore recommended that the correct pipe orientation is achieved.

2.11 Thoroughly flush the hot and cold water supply pipes. The supplies must be clean and free from debris before connecting the shower control. Failure to do so may result in product malfunction.

2.12 Slide the compression nuts and olives over the supply pipes.

2.13 Insert the hot and cold supply pipes fully into the inlet nipples and slide the olives and compression nuts into place.

2.14 Use a suitable spanner to tighten the compression nuts. Protect the chrome plated surfaces with a cloth.

2.15 Refer to section: '**Commissioning and Control Assembly Installation, Flow Regulator Installation and Filter Access**' for details on the flow regulator installation.

2.16 Turn on the water supplies and check for any leaks.

2.17 Refer to section: '**Commissioning and Control Assembly Installation**'.

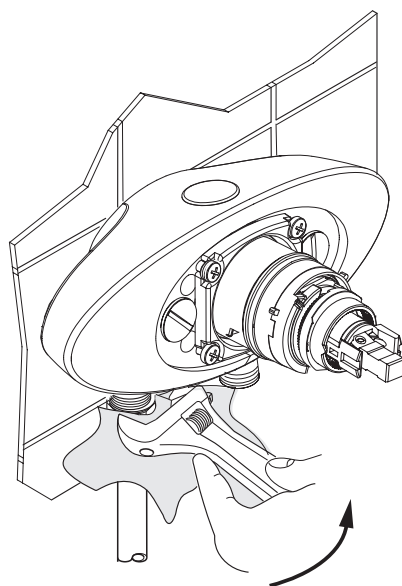
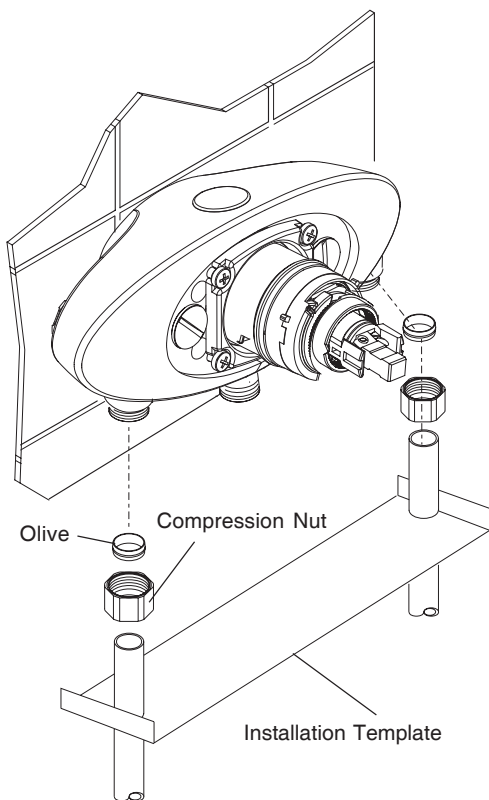

Falling Supplies

2.18 Follow the installation instructions 2.1 to 2.7.

2.19 Use the quad key to remove the outlet nipple.

2.20 Carefully lever the outlet cap from the outlet blanking plug in the shower control body.

2.21 Use the quad key to remove the outlet blanking plug.

2.22 Fit the outlet nipple, complete with 'O' seal into the hole previously blanked. Tighten the outlet nipple with the quad key.

2.23 Fit the outlet blanking plug, complete with 'O' seal, into the outlet hole between the two inlet nipples. Tighten the outlet blanking plug with the quad key.

2.24 Fit the outlet cap correctly. The matching contours of the outlet cap and shower control body must be aligned.

2.25 Locate the Combiflow shower control on to the wall.

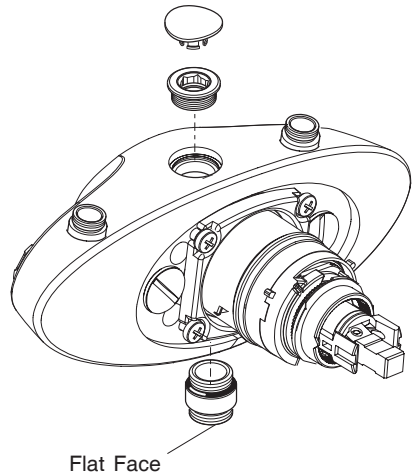
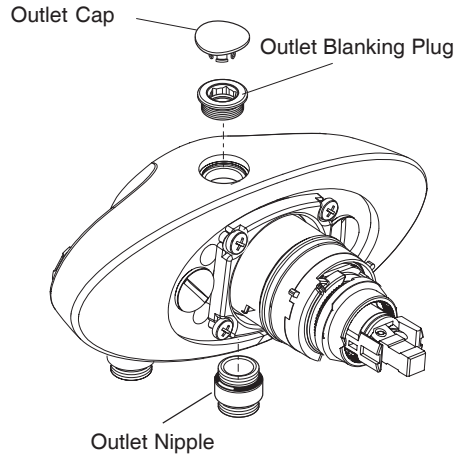

2.26 Use a suitable screwdriver to tighten the two screws through the body. The screws will hold the shower control in position.

2.27 Install the hot and cold supply pipes 35 mm from the finished wall at 153 mm centres.

Use the installation template to make sure the pipes are in the right position.

2.28 Refer to section: '**Reversed Inlet Connections**' and follow instructions 8.2. to 8.10. This will put the cartridge assembly, the indicator trim and the temperature knob in the correct orientation for **hot left** and **cold right** inlet supplies.

2.29 Follow the installation instructions 2.12. to 2.15. inclusive.

2.30 Refer to Commissioning for details on the flow regulator installation.

2.31 Turn on the water supplies and check for any leaks.

2.32 Refer to section: '**Commissioning and Control Assembly Installation**'.

Shower Fittings.

2.33 Install the shower fittings. Refer to the Installation and User Guide for the shower fittings.

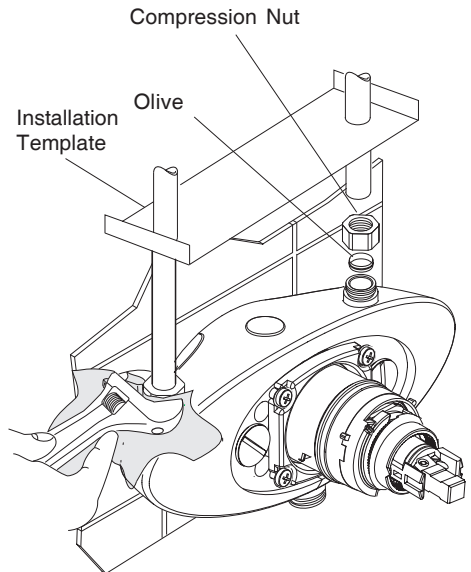
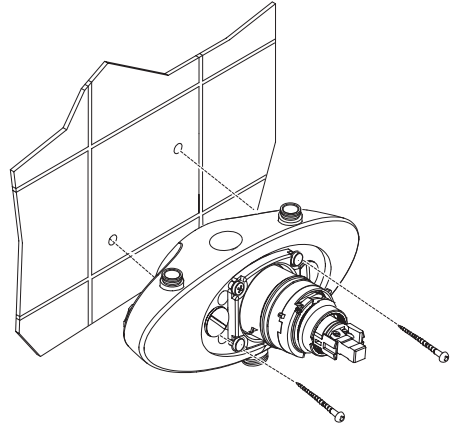

Combiflow B

3. Solid and dry-lined walls

Read the section “**Installation Requirements**” first.

The built-in shower control is supplied with support brackets that can be used to install the shower control into a solid or dry-lined wall structure.

3.1 Decide on a suitable position for the shower control. The position of the shower control and the shower fittings must provide a minimum gap of 25 mm between the spill-over level of the shower tray/bath and the handset. This is to prevent backsiphonage.

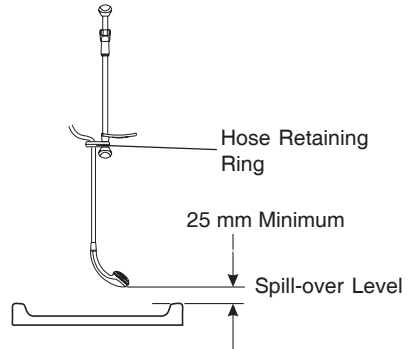

3.2 Determine the route for the incoming hot and cold supply pipework.

3.3 Determine the route for the outlet pipework. For further information on the installation of the **shower fittings** refer to the Installation and User Guide.

Note! The Combiflow B is supplied with inlet connections **hot left, cold right** and **top outlet** as standard. For installations with reversed hot and cold refer to section: '**Reversed Inlet Connections**'.

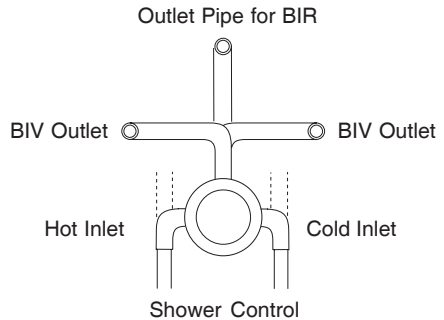

For installations with reversed hot and cold supplies a reversed temperature lever will be required. Available from Kohler Mira Customer Services. It is therefore recommended that the correct pipe orientation is achieved.

3.4 Remove the building in shroud.

Note! If the Combiflow B is to be fitted with top inlets then the bottom inlet compression fittings must be swapped using the quad key with the top inlet blanking plugs. Make sure all seals are fitted and components are tightened.

Refer to section: '**Exposed Inlet Supplies (rising or falling surface pipework)**' and follow instructions 2.4 to 2.5.

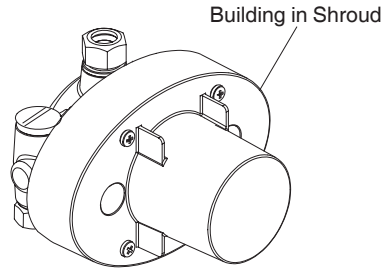

3.5 Fit the two brackets (supplied) to the mixer using the 2 x M4 x 8 mm screws (supplied).

Note! These can be fitted diagonally as required to enable easy fitting and access of the inlet connection.

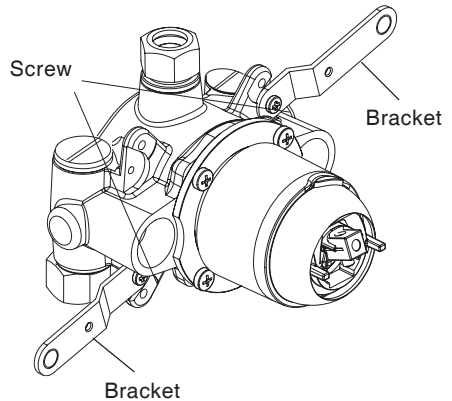

3.6 If installing the shower into a solid wall, mark an opening sufficient to accommodate the shower control approximately 245 mm x 145 mm on the surface of the wall.

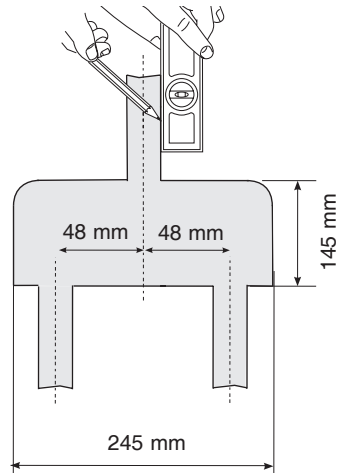

3.7 Mark the route of the inlet and outlet pipes.

3.8 Remove the plaster and brick/block for the shower control to a depth between **47 and 70 mm** from the finished surface of the wall, with a finished wall surface thickness between **6 and 23 mm**.

3.9 Remove the plaster and brick/block for the inlet and outlet pipes.

3.10 Mark the support bracket fixing hole positions.

Note! Support brackets can be adjusted to find a secure fixing and ensure easier spanner access to compression connections. The support bracket should be positioned so that the valve can be fitted level and the compression fittings can be easily tightened.

3.11 Drill a 6 mm diameter hole at each of the marked positions and insert the wall plugs (supplied).

Note! For stud partition installations alternative fixings may be required. Alternatively the support brackets can be removed and the two mounting holes in the body can be used to fit to the wall cavity or to a timber nogging.

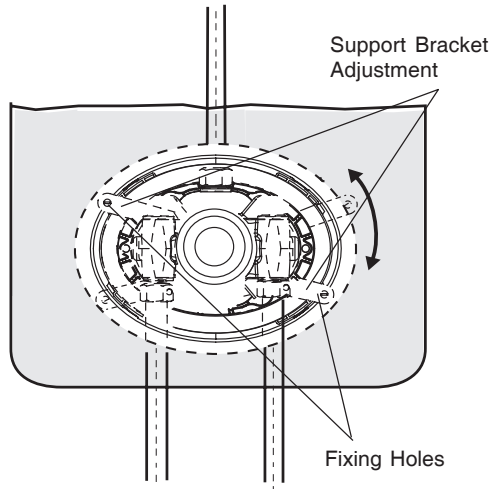
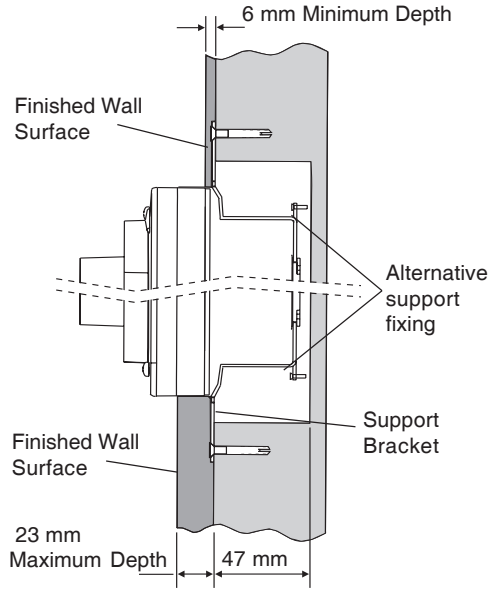

To make sure that the shroud fully locates over the body of the **Combiflow B**, the tabs on the building-in shroud **MUST** be bent inwards where the shroud meets the mounting brackets (refer to illustration).

Note! If using the fixing holes on the body casting to fix to the back wall or wooden noggin, the mounting brackets are not required and therefore you do not need to bend back the tabs.

Failure to carry out this procedure will result in the 'min' to 'max' building in depth shown on the shroud being incorrect.

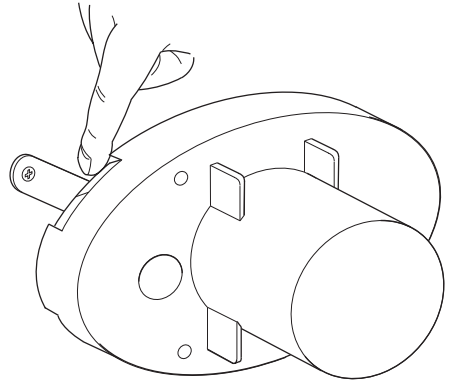

3.12 Temporarily fit the building-in shroud.

Check that the valve is level. Align the holes in the support bracket with the holes in the wall and secure the unit with the two fixing screws (supplied). Remove the building-in shroud to allow access to pipe connections.

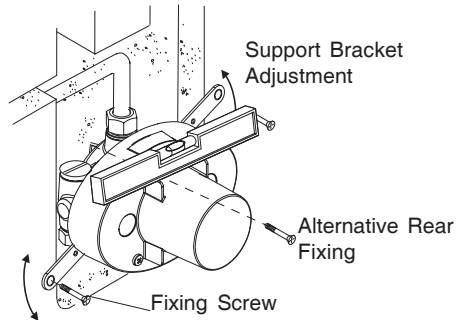

3.13 Align the hot and cold supply and outlet pipes with the valve but do not connect to the valve.

3.14 The supplies must be clean and free from debris before connecting the shower control. Failure to do so may result in product malfunction.

Note! The Combiflow is supplied with inlet connections **hot left, cold right** and **top outlet** as standard. For installations with reversed hot and cold refer to section: '**Reversed inlet connections**'.

For installations with reversed hot and cold supplies a reversed temperature lever will be required. Available from Kohler Mira Customer Services. It is therefore recommended that the correct pipe orientation is achieved.

3.15 Insert the hot and cold supply and outlet pipes through the compression nuts and olives. **Make sure that each pipe is pushed fully into the valve.**

Note! For BIV outlet with falling inlet supplies the inlet pipes may have to be set deeper into the wall.

3.16 Hold each pipe in position and use a suitable spanner to tighten the compression nuts.

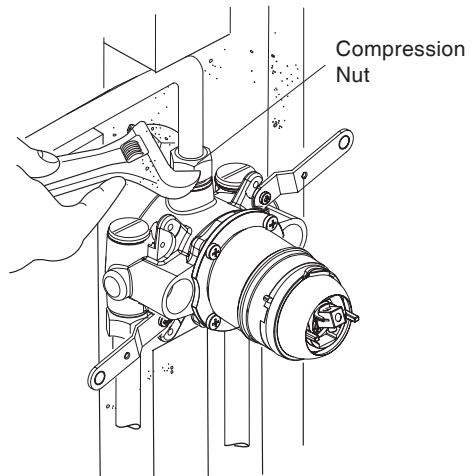
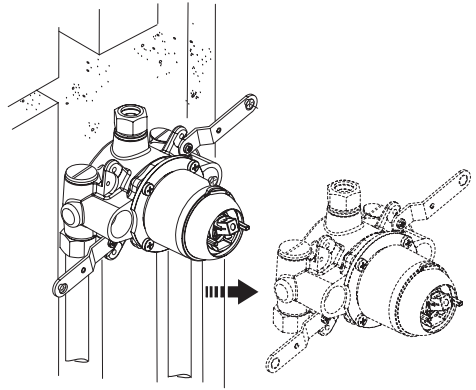

Note! Before turning on the water supplies refer to section: **'Commissioning and Control Assembly Installation'**.

3.15 Turn on the water supplies and check for any leaks.

3.16 Refit the building-in shroud removed earlier. Secure the shroud in position with the screws.

3.17 Plaster and tile as necessary up to the sides of the building-in shroud. Make sure that the finished tiled wall surface is within the area as shown on the building in shroud.

3.18 When the plaster/tiles have set, remove the screws and pull the entire building-in shroud away. Retain the screws for later use.

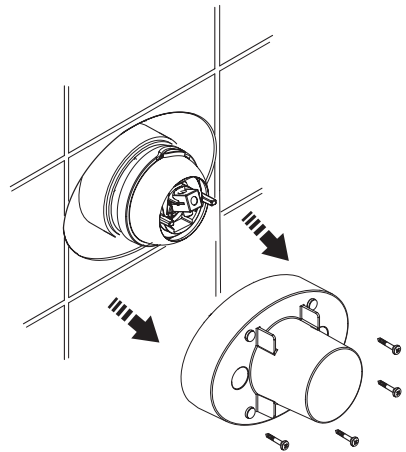
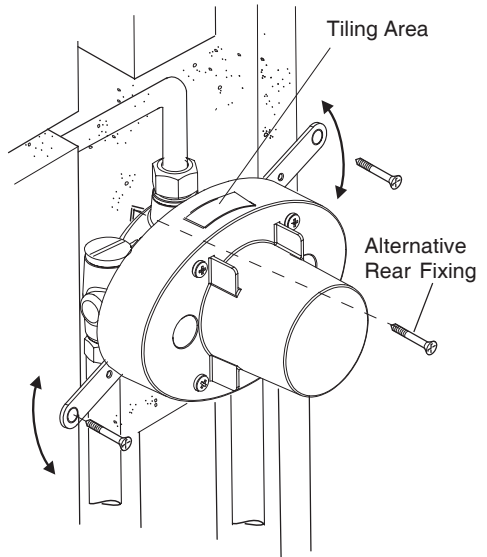

3.19 Remove the backplate from the concealing plate and fit in position with the screws provided.

Note! For shallow building in depths and front face panel mounting use the two short M5 x 25 mm screws (provided) in line with the inlet pipework.

Do not overtighten the screws as this may distort the valve position within the wall.

Note! If the finish is particularly uneven (i.e. due to grout lines), apply a small amount of silicone sealant to ensure a seal.

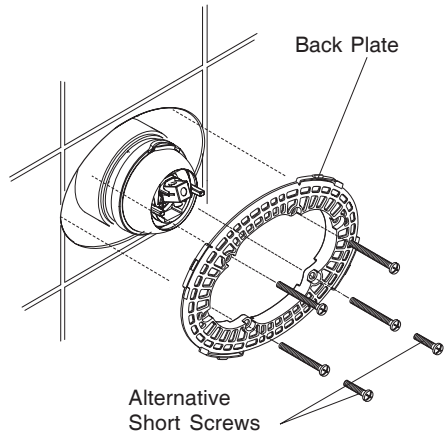

3.20 Slide the foam seal over the chrome shroud and align onto the back plate.

3.21 Fit the concealing plate over the shroud. Firmly push the concealing plate until it clips into position onto the backplate.

3.22 Carefully slide the concealing plate into position over the shroud. Firmly push until it clips to the backplate.

3.23 Fit the control lever assembly refer to section: '**Commissioning and Control Assembly Installation**'

Shower Fittings

3.24 Install the shower fittings. Refer to the shower fittings Installation and User Guide.

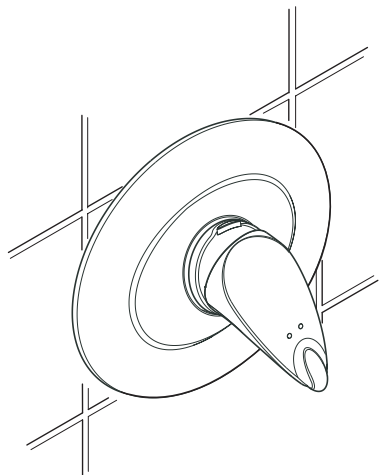
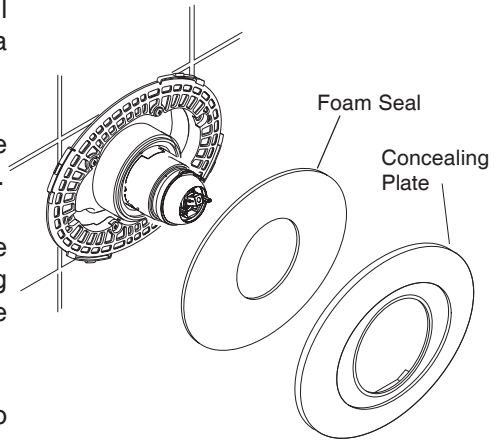

4. Stud Partitions and Shower Enclosures (Front Face)

Read the section “**Installation Requirements**” first.

The built-in shower control is supplied with support brackets that can be used to install the shower control into the front face of a stud partition wall structure or shower enclosures. The front face installation of the support bracket is only practical where an applied surface finish e.g. plaster or tiles can conceal the brackets.

4.1 Refer to section: '**Installation, 3. Solid and dry-lined walls**' and follow instructions 3.1. to 3.3.

4.2 Use the installation template (supplied) to mark the size of the hole required in the partition/enclosure. Bend the tabs inwards and use a spirit level to make sure that the hole is marked symmetrically. Mark around the **outside edge** of the template.

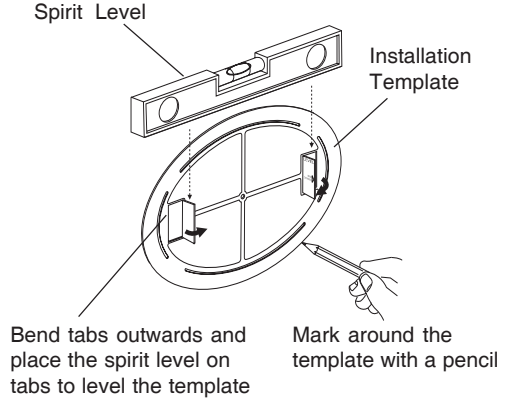

4.3 Carefully cut the hole in the panel.

Note! The valve requires a clearance depth of **47 mm**, with a panel/wall thickness of up to **17 mm**. The area shown on the building-in shroud can be used as a depth gauge. Panel/wall thicknesses in excess of 17 mm can be accommodated, but clearance may be required around the outlet and inlet connections to allow insertion of the pipe and tightening of the compression nut.

4.4 To complete the installation, refer to section: '**Installation, 3. Solid and dry-lined walls**' and follow instructions 3.8 to 3.23.

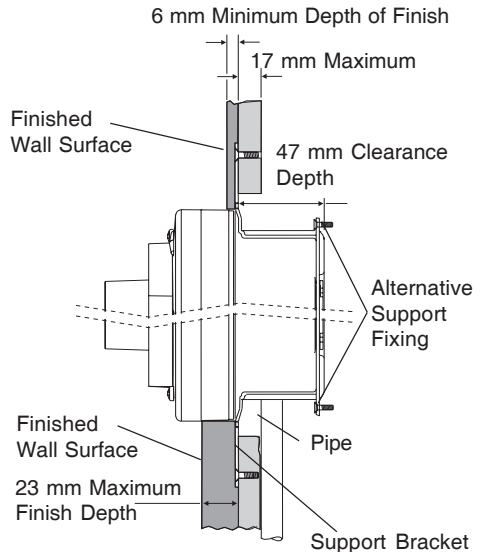

5. Laminated Panels and Shower Enclosures (Rear Face)

Read the section '**Installation Requirements**' first.

The built-in shower control is supplied with support brackets that can be used to install the shower control onto the rear face of a laminated panel or preformed shower cubicle.

Note! This installation is possible with a finished wall thickness of between **4 and 21 mm**.

5.1 Refer to section: '**Installation, 3. Solid and dry-lined walls**' and follow instructions 3.1. to 3.3.

5.2 Use the installation template (supplied) to mark the size of the hole required on the panel.

Bend the tabs inwards and use a spirit level to make sure that the hole is marked symmetrically.

Mark through the **inner slots** of the template.

5.3 Carefully cut the hole in the panel.

Note! The valve requires a clearance depth of **47 mm**, with a finished wall thickness of between **4 and 21 mm**

5.4 Drill a 5 mm diameter hole at each of the marked positions.

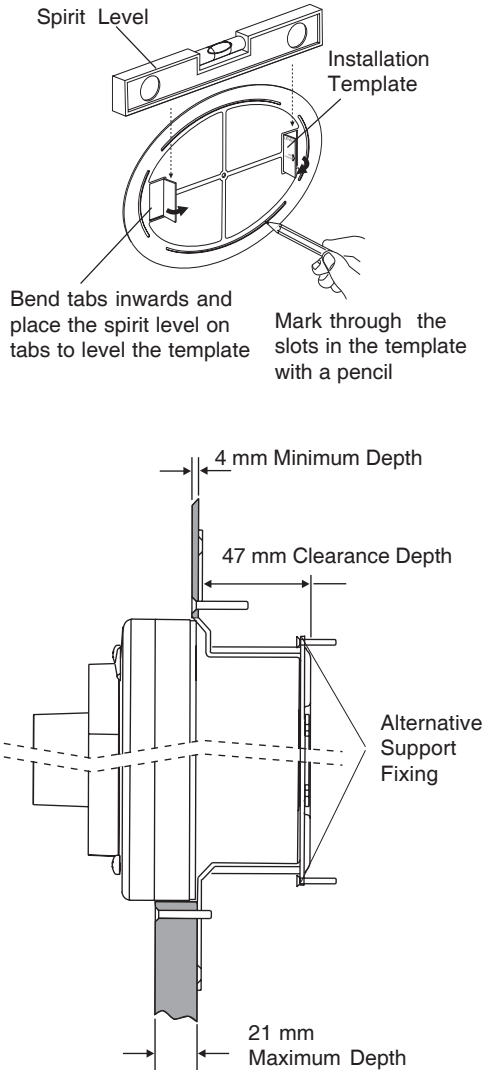

5.6 Remove the building-in shroud and fix the support brackets and valve in position using the two M4 x 30 mm screws (supplied).

5.7 Align the hot and cold supply and outlet pipes with the valve but do not secure the pipes.

5.8 To complete the installation, refer to section: '**Installation, 3. Solid and dry-lined walls**' and follow instructions 3.11 to 3.23.

Note! For stud partition installations alternative fixing may be required. Alternatively the support brackets can be removed and the two alternative rear mounting holes in the body can be used to fit to the wall cavity or to a timber nogging.

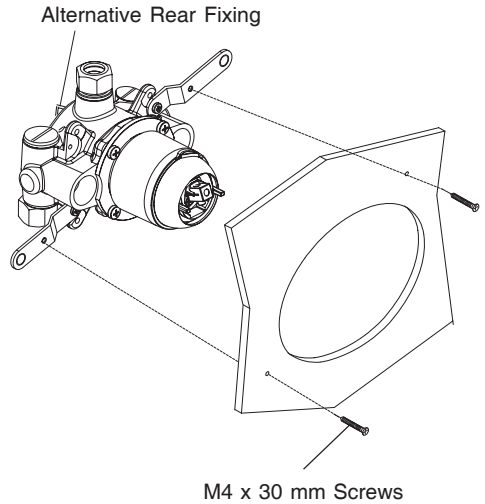

REVERSED INLET CONNECTIONS

The Combiflow exposed is supplied with back inlet connections **hot left, cold right** and **bottom outlet**.

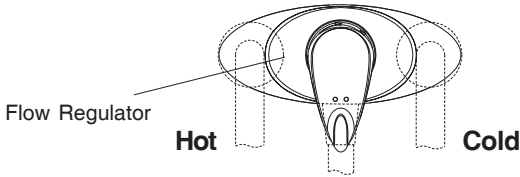

The Combiflow B is supplied with bottom inlet connections **hot left, cold right** and **top outlet**.

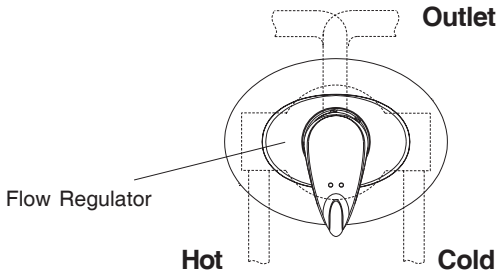

- 1.1** If the hot and cold inlet connections have been reversed during installation and cannot be corrected then a reversed lever with the red and blue indicators fitted in reverse will be required to indicate correct operation. (Available from Kohler Mira Customer Service).

Important! The flow regulator must always be installed in the hot side of the valve. Therefore if the hot and cold inlet connections have been reversed make sure that the flow regulator is fitted in the filter housing on the hot side of the valve. Refer to section: '**Commissioning and Control Assembly Installation**' for the flow regulator installation instructions.

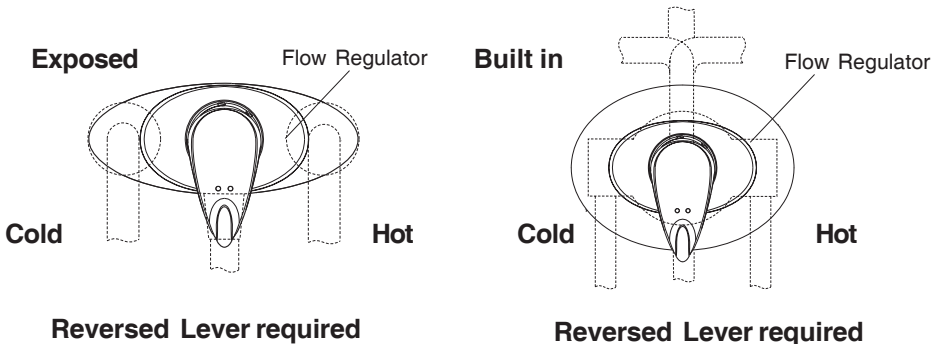

The shower control should be installed with hot on the left and cold on the right. If the inlet positions are changed, i.e. top inlets are used then the internal cartridge must be turned through 180° to enable the lever control to operate correctly.

The following procedure must be performed:

1.2 If the water supply has been connected and turned on, isolate the supplies and operate the control lever to relieve the pressure.

1.3 Carefully pull off the control lever and shroud assembly. (refer to section: '**Commissioning and Control Assembly Installation**').

1.4 Remove the four cartridge retaining screws (refer to section: '**Maintenance**').

1.5 Remove the upper body / flow cartridge assembly (refer to section: '**Maintenance**').

1.6 Lever the pressure balancing cartridge from the body and rotate the cartridge 180° and replace.

Caution! Take care not to damage the two inlet seals during assembly (refer to section: '**Maintenance**').

1.7 Refit the upper cartridge body and make sure that the two ports are aligned with the two ports on the pressure balancing cartridge.

1.8 Refit the four cartridge retaining screws.

Caution! The upper cartridge must be fully pushed onto the pressure balancing cartridge before securing with the retaining screws. If the upper cartridge seal is visible then the cartridges are not aligned correctly.

1.9 Restore the hot and cold supplies and check for leaks.

1.10 Refit the shroud and the control lever assembly (refer to section: '**Commissioning and Control Assembly Installation**').

If the seal is visible then the cartridges are not aligned and fully engaged

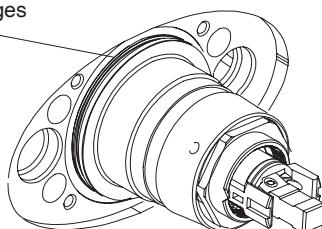

COMMISSIONING AND CONTROL ASSEMBLY INSTALLATION

Flow Regulator Installation and Filter Access

For most combination boiler and instantaneous water heater installations an 8 l/min flow regulator (supplied fitted) is required in the hot supply of the shower mixer control. This is to ensure a regular flow and thus a stable temperature.

Note! For other high pressure systems removal of the 8 l/min flow regulator (supplied fitted) is recommended.

The flow regulator is fitted into the inlet filter housing as illustrated below.

Note! Make sure the flow regulator is fitted in the correct orientation either for the Combiflow exposed or built-in (refer to illustrations below).

To access filters or the flow regulator once the shower has been installed, remove the cover shroud (Combiflow exposed) or the concealing plate (Combiflow Built In).

Make sure that the 8 l/min white flow regulator is fitted for combination boiler and instantaneous water heater systems.

Remove the flow regulator for high pressure and pumped systems.

Exposed

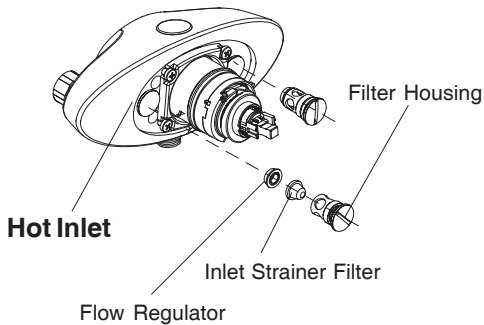

Built-in

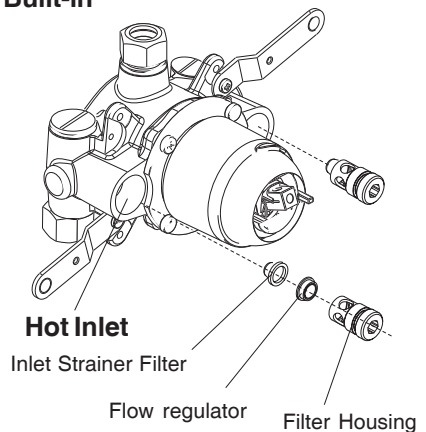

Shroud Fitting and Removal

Combiflow Exposed

Fit the shroud assembly.

1. Make sure that the override button assembly is aligned at the 1 O' clock position.
2. Engage the shroud into the body recess and push the shroud firmly onto the body.

Note! Make sure that the override button is firmly in position inside the shroud and the grey button guide is positioned correctly on the body. Failure to fit the shroud correctly may cause the control lever to rub on the shroud..

For removal hold the shroud firmly and pull away from the valve.

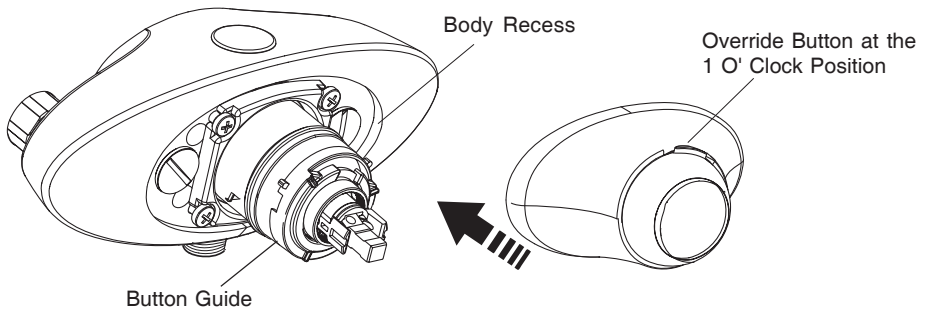

Combiflow Built in

The shroud assembly is supplied fitted, if it is removed then follow this procedure.

1. Make sure that the override button assembly is aligned at the 1 O' clock position.
2. Make sure that the five raised locators within the shroud assembly fit into the five slots of the brass upper body and push the shroud firmly onto the body.

Note! Make sure that the override button is firmly in position inside the shroud and the white button guide is positioned correctly on the body. Failure to fit the shroud correctly may cause the control lever to rub on the shroud.

For removal hold the shroud firmly and pull away from the valve.

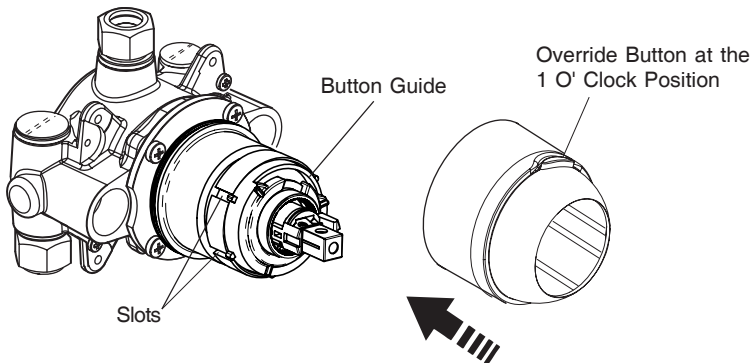

Maximum Temperature Setting

Read all the sections: **Maximum temperature setting, Adjusting Maximum Temperature Stop and Temperature Override Button Disable** before carrying out any of these procedures.

The following instructions are valid for both, Combiflow Exposed and Combiflow Built in.

- 1.1** The Combiflow maximum temperature stop assembly is set to nominally 41 °C at the factory (**Note! This may vary according to the on-site water temperatures**). This equates to the two missing teeth of the white geared maximum temperature stop ring being fitted in line with the raised part of the plastic moulding on the red lever stop (as shown in the illustration). If the shower has reversed inlets then approximately 41 °C equates to the two missing teeth being fitted in line with the large locator on the red lever stop ring (as shown in the illustration).

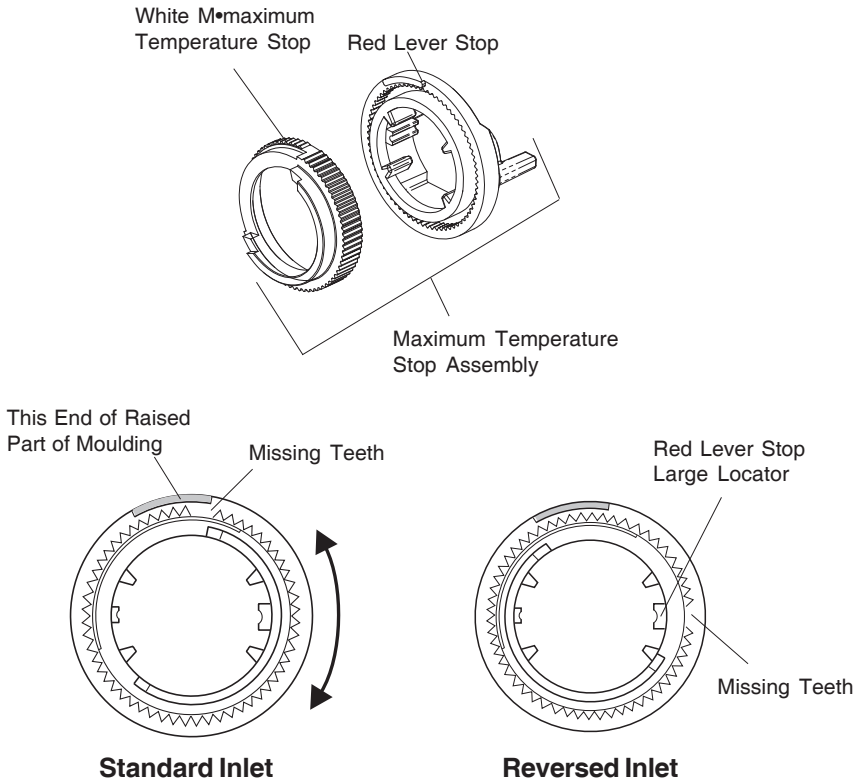

Rear View of Maximum temperature Stop Assembly

- 1.2** For standard inlets turn the square lever locator fully anticlockwise and clockwise for reversed inlet.

Fit the maximum temperature stop assembly into the two slots either side of the square lever locator on the shower control (**Note!** Make sure that the maximum temperature stop assembly has the red side facing towards you. One slot is wider than the other to make sure of correct installation, see illustration below). Push the maximum temperature stop fully on.

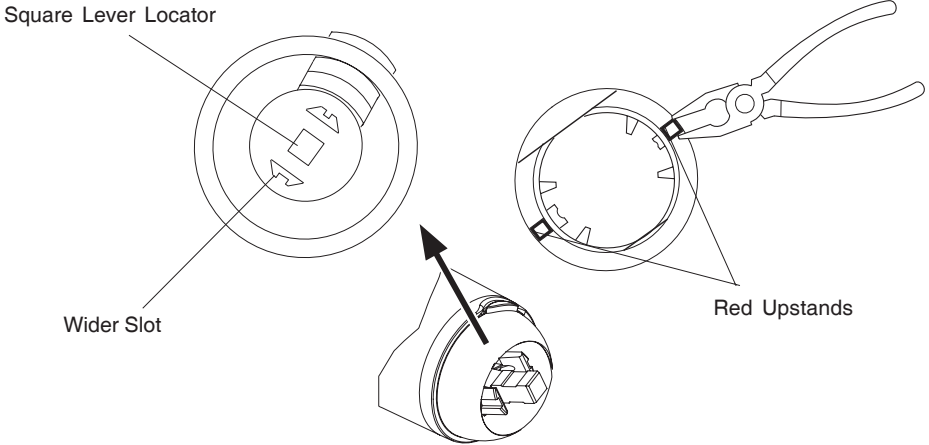

Front View standard inlet

- 1.3** Fit control lever onto square lever locator (see fitting control lever).

Lift lever towards you to turn the shower on to give a typical shower force.

Turn lever clockwise to increase temperature until movement stops and allow temperature to stabilise. If this maximum temperature is satisfactory, then firmly tighten grub screw and fit grub screw cover. If the temperature is not satisfactory refer to 9.4.

(Note! For reversed inlets a reversed inlet control lever is required. Anticlockwise movement will increase temperature. If the maximum temperature is not satisfactory then the maximum temperature stop will require adjustment.

Adjusting Maximum Temperature Stop

- 1.4** To adjust the maximum temperature position remove the lever.
Remove the red maximum stop ring by pulling on two red upstands
(Use pliers if necessary)

Standard Inlets

Pull the white maximum temperature stop apart from the red maximum lever stop (Use pliers if necessary). Turn the white gear 1 or 2 gear teeth clockwise to increase the maximum shower temperature or anticlockwise to decrease. **(Note!** One gear tooth movement will increase or decrease the temperature by approximately 2 °C) push together firmly.

Fit the red maximum temperature stop as described in **9.2**.

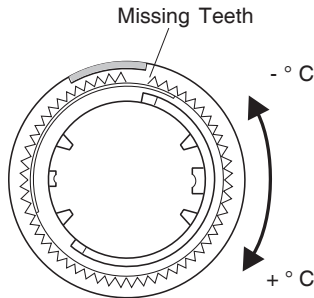

Rear View of Maximum Temperature Stop Assembly

Reversed Inlets

Pull the white maximum temperature stop apart from the red maximum lever stop (Use pliers if necessary). Turn the white gear 1 or 2 gear teeth anticlockwise to increase the maximum shower temperature or clockwise to decrease.

(Note! One gear tooth movement will increase or decrease the temperature by approximately 2 °C) push together firmly.

Fit the red maximum temperature stop as described in **9.2**.

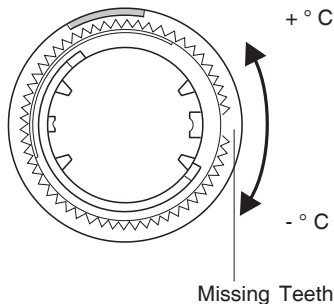

Rear View of Maximum Temperature Stop Assembly

Temperature Override Button - Disable

The Combiflow incorporates a temperature override button that allows the user to override the preset maximum temperature. The following procedure can be used to disable the override button, limiting the maximum temperature available to the preset value. This setting is recommended for the young, the elderly, the infirm, or anyone inexperienced in the correct operation of the controls.

1.5 Carefully remove the control lever.

1.6 Slot the white disabler button component into the red lever stop ring and push fully in.

Note the two positions (See illustration).

Note this is already in the stored position in the Combiflow B.

1.7 Refit the control lever.

1.8 Reversing the above procedure will enable the override button.

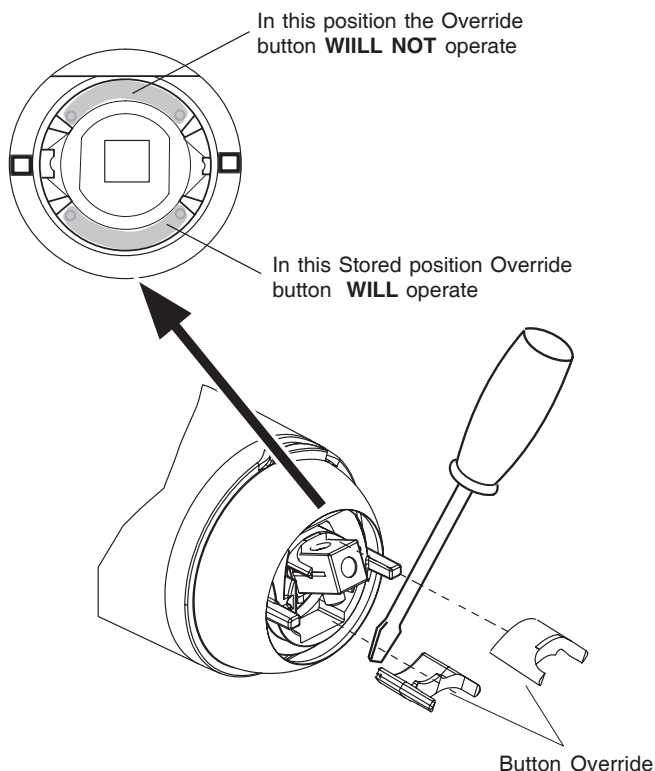

Lever Control Installation

Fit control lever

Push the control lever over the square lever locator and make sure that the lever is pointing down.

Tighten the grub screw with the extra long 2.5 mm hexagonal key (supplied) and fit the grey handle plug.

Note! It is easier to locate the hexagonal key into the grub screw before fitting the lever.

Fit the lever plug after all of the maximum temperature commissioning has been carried out.

Combiflow Exposed

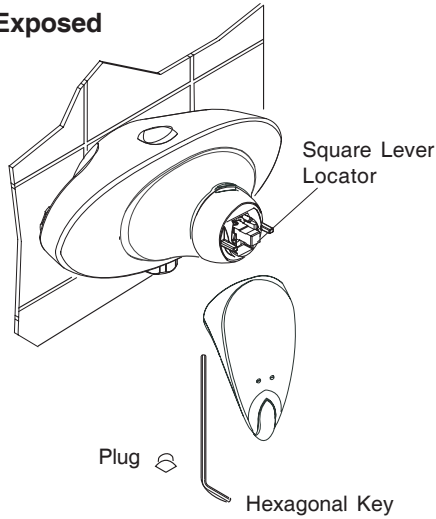

Combiflow Built in

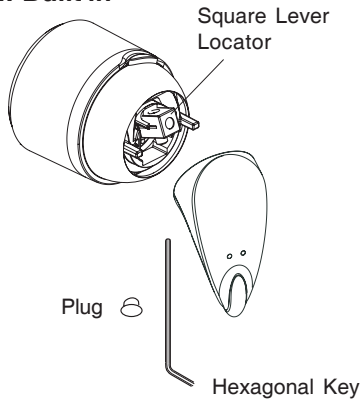

OPERATION

1. Combiflow and Combiflow B

The Combiflow incorporates a temperature override button that allows the user to override the preset maximum temperature.

- 1.1** Pull the control lever to turn on the water. Push the control lever to turn off the water.

Note! When the Combiflow is installed with a fully modulating multipoint or combination type gas water heater, the maintained mains water pressure, and hence the flow, must be sufficient to keep the heater ignited. Therefore, it is important to make sure that the flow knob is used in the fully open position to help prevent variation in the hot water supply temperature.

Warning! The Mira Combiflow is not a thermostatic mixer valve, reducing the flow by operating the control lever during showering may increase the temperature.

- 1.2** Turn the lever clockwise for warmer water or anti clockwise for cooler water.

Caution! Operation will be in reverse if the reversed lever is being used. The preset maximum temperature can be adjusted as required to suit both site conditions and the user's comfort. Refer to section: '**Commisioning and Control Assembly Installation, Maximum Temperature Setting**'.

Warning! Operation of the override button will allow a shower temperature above the preset maximum.

- 1.3** To override the preset maximum temperature depress the override button and turn the temperature knob further clockwise while keeping the button depressed.

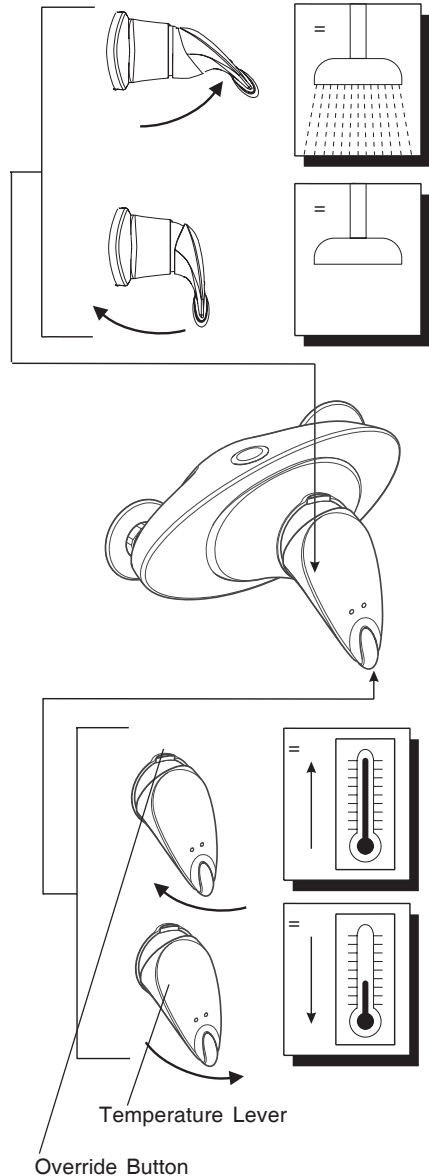

FAULT DIAGNOSIS

The trouble shooting information tabled below gives details on what you can do as a user should you encounter difficulties whilst operating the shower.

Note! Should these remedies prove to be unsuccessful in solving your problem, contact your installer for further advice.

Key for applicability column

A - Instantaneous gas heated showers.

B - Unvented mains pressure showers/gravity pumped showers.

C - Mains pressurised, instantaneous hot water, heated from thermal store showers.

Malfunction	Cause	Remedy	A	B	C
Shower insufficiently hot.	(a) Maximum temperature incorrectly set.	Reset adjustable maximum temperature.	✓	✓	✓
	(b) Heater not set on maximum hot.	Consult heater instructions or contact a CORGI registered installer.	✓		
	(c) Flow rate still too high.	Fit the flow regulator into hot inlet (Refer to flow regulator installation)	✓	✓	✓
Wide temperature fluctuations from shower when no other draw-off is being made.	(a) Insufficient flow rate causing the heater to cycle on and off.	Check and clean inlet strainers. Make sure the flow control is fully on.		✓	
	(b) Insufficient water pressure causing the heater to cycle on and off.	Contact your local water supplier or a CORGI registered installer.		✓	
	(c) Heater not fully modulating.	Contact a CORGI registered installer.		✓	
	(d) See also ' Shower insufficiently hot '.			✓	
Shower pattern collapses when another hot tap is turned on.	(a) The heater cannot supply several outlets at the same time.	Reduce the simultaneous demand.	✓		✓
	(b) Inlet strainer blocked.	Check and clean inlet strainers	✓		✓

Malfunction	Cause	Remedy	A	B	C
Shower pattern collapses when another cold tap is turned on.	(a) Property water supply pipe partially blocked or undersized.	Contact the local water supplier or your installer.	✓	✓	✓
	(b) Property stop or servicing valve not fully open.	Open valve.	✓	✓	✓
	(c) Insufficient mains cold water pressure.	Contact the local water supplier or your installer.	✓	✓	✓
	(d) Inlet strainer blocked.	Check and clean inlet strainers.	✓	✓	✓
Shower gives hot water when turned cold and cold water when turned hot.	(a) Hot and cold water supplies have been connected in reverse.	Refer to section: 'Installation, Reversed Inlet Supplies' .	✓	✓	✓
Shower insufficiently hot without pressing red button and rotating further.	(a) Adjustable maximum temperature incorrectly set.	Refer to section: 'Commissioning and Control Assembly Installation, Maximum Temperature Setting' .	✓	✓	✓
Shower force too strong.	(a) Flow control fully open.	Reduce the flow. Refer to section: 'Operation' .	✓		✓
	(b) Pressure above 5 bar.	Contact installer to fit a pressure reducing valve.	✓	✓	✓
	(c) Flow regulator not fitted.	Fit flow regulator.	✓		✓
No hot water available.	(a) Heater appliance not igniting due to insufficient mains pressure or flow.	Contact the local water supplier or a CORGI registered installer.	✓		
	(b) Heater appliance not igniting due to appliance fault.	Contact a CORGI registered installer.	✓		
	(c) Product hot or cold isolating valve not fully open.	Open valve.	✓	✓	✓
	(d) Hot water run out.	Wait until reheated.		✓	✓
	(e) Inlet strainer blocked.	Check and clean inlet strainers.	✓	✓	✓

Malfunction	Cause	Remedy	A	B	C
Shower starts warm and then runs cool.	(a) Insufficient flow rate.	Refer to ' Wide temperature fluctuations '.	✓		
	(b) Hot water supply temperature dropped.	Wait for hot water to reheat.		✓	✓
Shower control cannot be shut off.	(a) Ceramic flow cartridge damaged.	Renew the cartridge. Refer to section: ' Maintenance, Cartridge Renewal '.	✓	✓	✓
	(b) 'O' seals damaged.	Renew 'O' seals with Service Pack.	✓	✓	✓
No flow or low flow from shower head.	(a) Supply stop valve turned down or off.	Open valve.	✓	✓	✓
	(b) Inlet Strainers blocked.	Clean or renew the inlet strainers.	✓	✓	✓
	(c) Hose or handset blocked.	Clear the blockage. If necessary renew the hose or handset.	✓	✓	✓
	(d) Spray plate blocked.	Remove and clean.	✓	✓	✓

MAINTENANCE

The Mira Combiflow is designed to be maintenance free, as such there are no serviceable parts within the flow or pressure balancing cartridge. However regular cleaning will keep the shower in pristine condition, refer to '**1. Cleaning**'. Strainers are fitted to the inlets of the mixer to protect the cartridge and should give many years of trouble free showering. Filters should be checked at yearly intervals and cleaned or replaced to maintain optimum shower performance. Refer to section: '**Commissioning and Control Assembly Installation, Flow Regulator Installation**' for details on the inlet filter location.

1. Cleaning

Many household cleaners contain abrasive and chemical substances, and should not be used for cleaning plated or plastic fittings. These finishes should be cleaned with a mild washing up detergent or soap solution, and then wiped dry using a soft cloth.

2. Ceramic Flow Cartridge Renewal

- 2.1 Refer to section: '**Reversed Inlet Connections**' and follow instructions 1.3 to 1.4.
- 2.2 Unscrew and remove the headnut and remove the ceramic flow cartridge. Replace with the new cartridge and make sure it is fitted in the correct orientation. Refit the headnut.
- 2.3 Refer to section: '**Reversed Inlet Connections**', instructions 1.10 to 1.11 and section: '**Commissioning and Control Assembly Installation**' to complete the installation of the new ceramic flow cartridge.

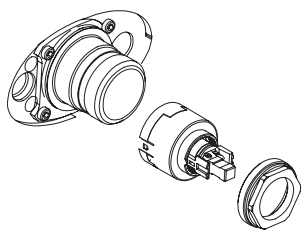

Carefully Lever Out

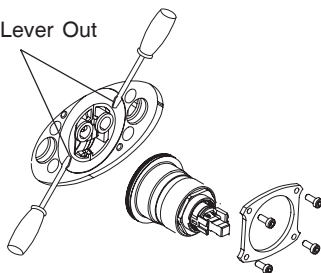

3. Pressure Balancing Cartridge Renewal

- 3.1 Refer to section: '**Reversed Inlet Connections**' and follow instruction 1.3 to 1.6.
Note! Before removing the pressure balancing cartridge note its position, to ensure the correct orientation of the replacement.
- 3.2 Lever the pressure balancing cartridge from the shower body. Fit the new pressure balancing cartridge and make sure it is fitted in the correct orientation.
- 3.3 Refer to section: '**Reversed Inlet Connections**' and follow instructions 1.8 to 1.10 and section: '**Commissioning and Control Assembly Installation**' to complete installation of the new pressure balancing cartridge.

SPARE PARTS

Combiflow Exposed Spare Parts List

459.01	Lever Handle
459.02	Lever Handle (Reversed)
459.03	Cover Shroud Assembly
459.05	Flow Cartridge Assembly
459.06	Flow Cartridge Body
459.07	Pressure Balancing Cartridge
459.08	Filter, Flow Regulator and Plug Pack
459.09	Inlet Connector Assembly
459.10	Outlet Nipple
459.11	Outlet Blanking Plug
459.12	Filter and Flow Regulator Pack
459.13	Screw Pack (Not Illustrated)
459.14	Seal Pack (Not Illustrated)
459.15	Component Pack (Not Illustrated)
459.16	Installation Template
459.20	Inlet Blanking Plug

Combiflow Exposed Spare Parts Diagram

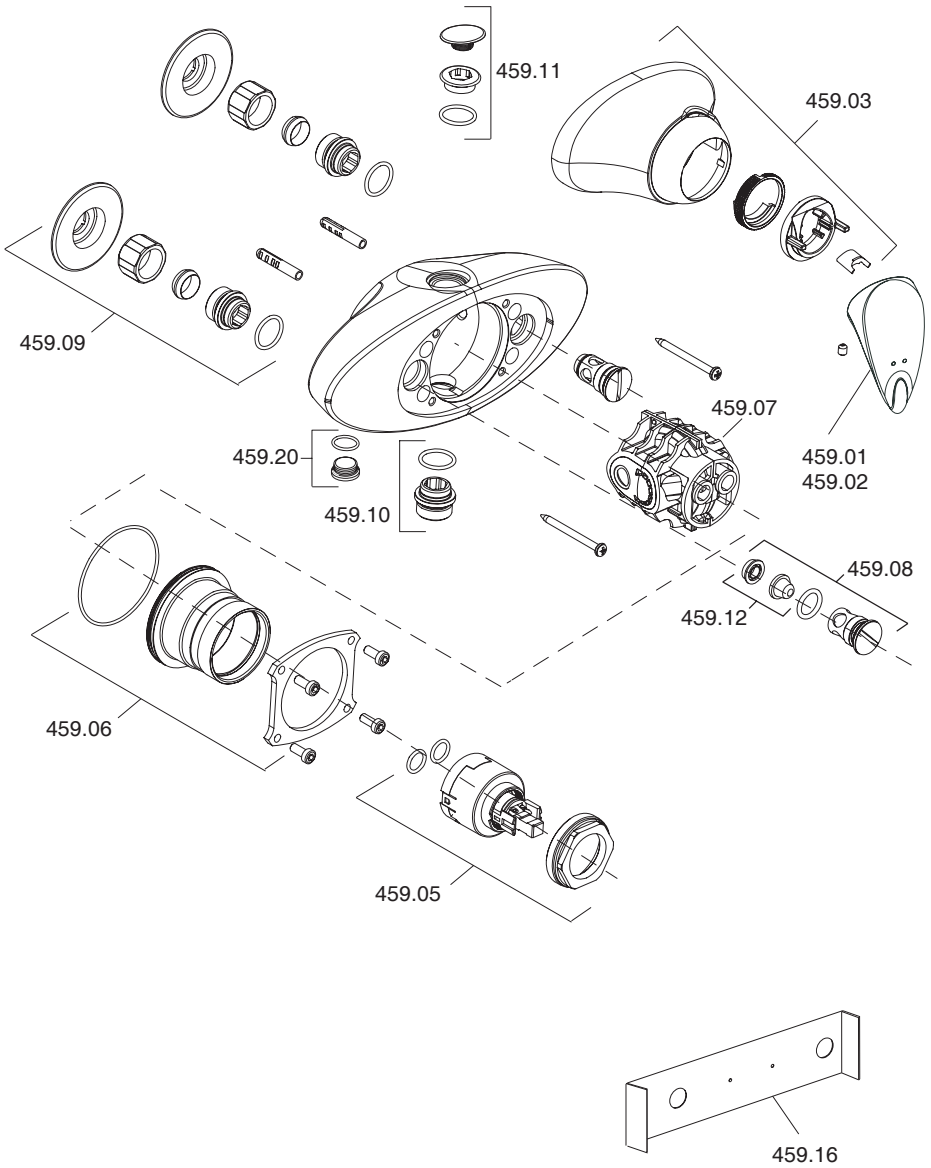

Combiflow Built in Spare Parts List

459.01	Lever Handle
459.02	Lever Handle (Reversed)
459.04	Cover Shroud Retaining Clip
459.05	Flow Cartridge Assembly
459.06	Flow Cartridge Body
459.07	Pressure Balancing Cartridge
459.12	Filter and Flow Regulator Pack
459.14	Seal Pack (Not Illustrated)
459.18	Cover Shroud Assembly
459.19	Concealing Plate Assembly
459.20	Inlet Blanking Plug
459.21	Outlet Connector Assembly
459.22	Screw Pack (Not Illustrated)
459.23	Wall Mounting Bracket
459.24	Component Pack (Not Illustrated)
459.25	Building-in Shroud
459.26	Installation Template
459.27	Inlet Connector Assembly
459.28	Filter, Flow Regulator and Plug Pack

Combiflow Built in Spare Parts Diagram

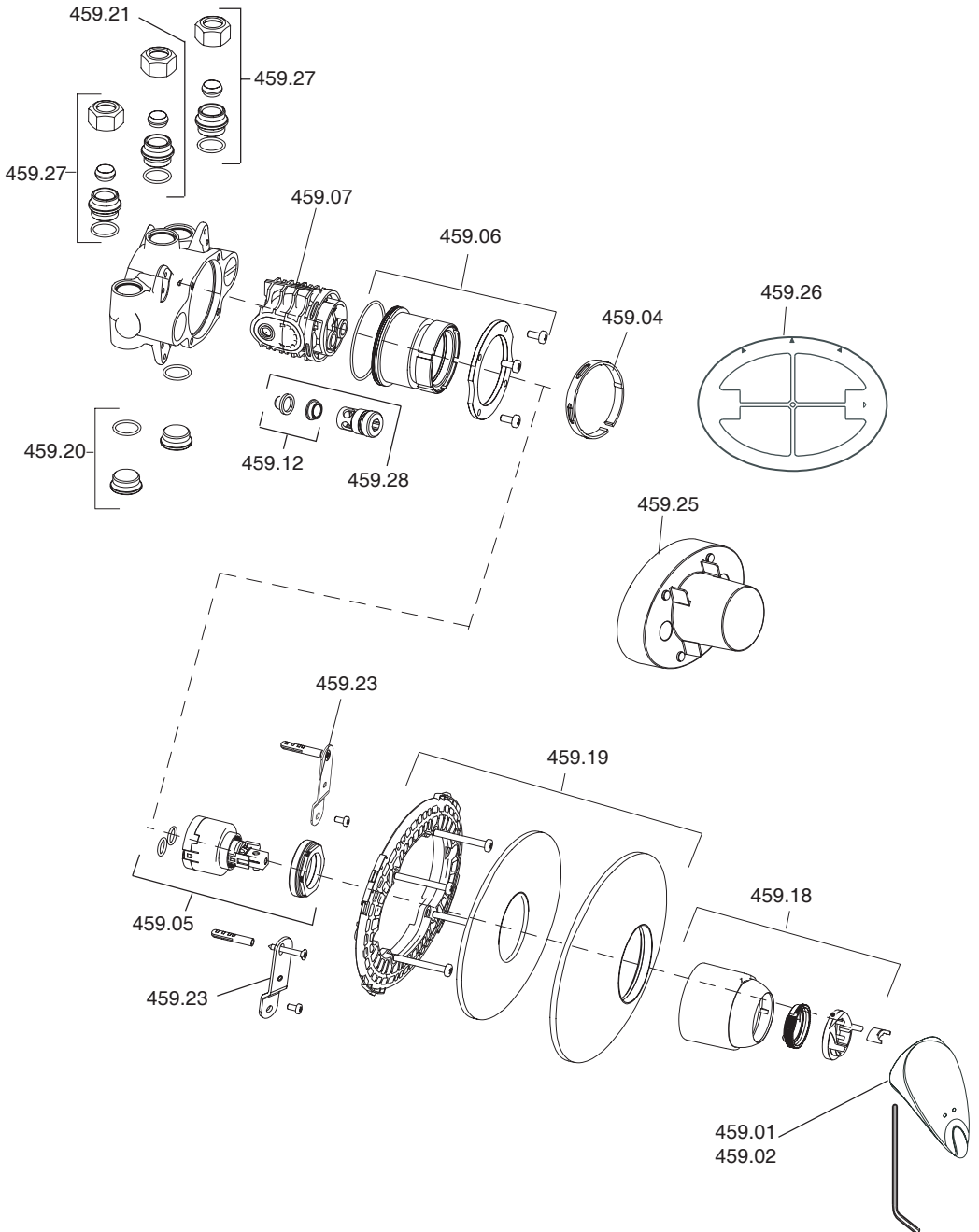

ACCESSORIES

DCV-H: An outlet double check valve, requiring a minimum inlet supply pressure of 0.5 bar, which has been designed to prevent the backflow or backsiphonage of potentially contaminated water, through shower controls which are fitted with a flexible hose as part of the outlet shower fitting.

Available as an optional accessory from your Mira stockist.

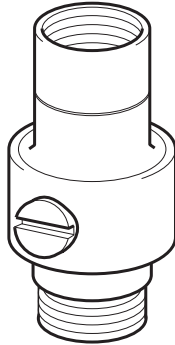

DCV-H Outlet double check valve

NOTES

CUSTOMER SERVICE

Guarantee of Quality

Mira Showers guarantee your product against any defect in materials or workmanship for the period shown in the Guarantee Registration Document included with your shower. Alternatively, to confirm the applicable guarantee period please contact Customer Services.

To validate the guarantee, please return your completed registration card.

Within the guarantee period we will resolve defects, free of charge, by repairing or replacing parts or modules as we may choose.

To be free of charge, service work must only be undertaken by Mira Showers or our approved agents in Northern Ireland and Republic of Ireland.

Service under this guarantee does not affect the expiry date. The guarantee on any exchanged parts or product ends when the normal product guarantee period expires.

Not covered by this guarantee:

Damage or defects arising from incorrect installation, improper use or lack of maintenance, including build-up of limescale.

Damage or defects if the product is taken apart, repaired or modified by any person not authorised by Mira Showers or our approved agents.

This guarantee is in addition to your statutory and other legal rights.

Before using your shower

Please take the time to read and understand the operating and safety instructions detailed in this manual.

What to do if something goes wrong

If when you first use your shower it doesn't function correctly, first contact your installer to check that installation and commissioning are satisfactory and in accordance with the instructions in this manual. We are on-hand to offer you or your installer any advice you may need.

Should this not resolve the difficulty, simply contact our Customer Services who will give every assistance, and if necessary arrange for our service engineer to visit.

If later the performance of your shower declines, consult this manual to see whether simple home maintenance is required. Please call our Customer Services to talk the difficulty through, request service under guarantee if applicable, or take advantage of our comprehensive After-Sales service.

As part of our quality and training programme calls may be recorded or monitored.

Our Customer Services Team is comprehensively trained to provide every assistance you may need: help and advice, spare parts or a service visit.

Spare Parts

We maintain an extensive stock of spares, and aim to have functional parts available for ten years from the date of final manufacture of the product.

Spares can be purchased from approved stockists or merchants (locations on request) or direct from Customer Services.

Spares direct will normally be despatched within two working days. Payment can be made by Visa or Mastercard at the time of ordering. Should payment by cheque be preferred a pro-forma invoice will be sent.

Note! In the interests of safety, spares requiring exposure to mains voltages can only be sent to competent persons.

Service

Our Service Force is available to provide a quality service at a reasonable cost. You will have the assurance of a Mira trained engineer/agent, genuine Mira spares, and a 12 month guarantee on the repair.

Payment should be made directly to the Service Engineer/Agent, using Visa, Mastercard or a cheque supported by a banker's card.

To contact us

England, Scotland & Wales

Mira Showers Customer Services

Telephone: 0870 241 0888

8:30 am to 5:00 pm Working days (4:30 pm Friday)

8:30 am to 12.30 pm Saturday

E-mail: technical@mirashowers.com

Fax: 01242 282595

By Post: Cromwell Road
Cheltenham
Gloucestershire
GL52 5EP

Northern Ireland

Wm H Leech & Son Ltd

Telephone: 028 9044 9257 – Mon to Fri 9 am-5pm

Fax: 028 9044 9234 – 24 hours

Post: Maryland Industrial Estate
Ballygowan Road
Moneyreagh, Co Down
BT23 6BL

Republic of Ireland

Modern Plant Ltd

Telephone: 01 4591344 – Mon to Fri 9am to 5pm

Fax: Dublin 01 4592329 – 24 hours

Post: Otter House
Naas Road
Clondalkin
Dublin 22

Mira Showers

Kohler Mira Ltd
Cromwell Road,
Cheltenham GL52 5EP.

Mira is a registered trade mark of
Kohler Mira Limited.

The company reserves the right to alter
product specifications without notice.

www.mirashowers.com



FM 14648

